



TKA LabTower UP/UPW



The High-Tech complete system. High purity water for a wide range of laboratory and medical applications.

TKA WATER
PURIFICATION
SYSTEMS

The integrated system. Purification and storage in one.



■ **This High-Tech complete system has been specifically designed for laboratory and medical areas**

The high purity water quality produced fulfills all requirements on rinse water for medical use acc. to pr EN15883, DIN EN 285/13060 standards...

- For supplying cleaning and disinfecting equipment for surgical instruments, vessels and glassware as well as anesthetic equipment
- For supplying autoclaves and steam sterilizers

...and on laboratory water acc. to ASTM II, CAP, ISO 3696 standards

- For feeding ultra pure water systems
- For glassware rinsing
- For preparing and diluting buffers, reagents
- For preparing samples for analytical methods
- For general biotechnological applications

TKA LabTower UP/UPW.



The benefits in a nutshell!

Excels as a laboratory supplier!

- Combination of a high performance reverse osmosis module with long-life ion exchanger
- Twosystems, for either 20 or 40 litres of high purity water per hour

Compact, attractive design, movable!

- Needs no bench-top space
- Amere ¼ m² floor space suffices
- Castors allow easy re-location

Dependable operation!

- Microprocessor control directs automatic operation and monitors all important parameters
- Potential-free contact allows fault message evaluation
- Leak monitoring via AQUASTOP water control with solenoid valve (optional)

Water quality always fresh!

- Accurate water quality data are assured via the built-in RS 232 interface and printed out
- Purification and quality measurement immediately before high purity water is drawn off



Two in one!

- Reverse osmosis water purification together with high purity water tank
- Twosystems in a single whole

Two ways to dispense water!

- Directly from the system via the dispensing valve for calibration solution preparation, manual analyses, filling of containers, general rinsing purposes, etc.
- From the tank for direct supply to autoclaves, washing machines, ultra pure water systems

Built-in state-of-the-art technology!

- Water pretreatment with 5 µm pre-filter, activated carbon and hardness stabilization
- 1µm Particle removing filter at the tank outlet of high purity water

Optionally with:

- Sterile filter unit for the tank water outlet
- Sterile vent filter/overflow
- UV immersion lamp for installation in the tank
- Flowthrough UV sanitization of high purity water (UPW version only)

Greater economy!

- Low running costs are ensured by the stainless steel cartridge containing a 20 l stock of ion exchange resins. These TOC tested resins can be simply replaced by disposable resin and/or be regenerated



■ Store high purity water safely and conveniently!

100 Litre tank module!

- Up to 100 litres of high purity water ready for dispensing when needed

Sterile vent filter/tank overflow (optional)

- These two protective filters prevent airborne contamination by micro-organisms

Volume display/float chain

- Completely automatic level regulation with display of the currently stored volume in the tank
- Float chain for adjustable tank volume

Polyethylene tank

- High purity water resistant, opaque to light and food-safe
- Comfortable access via the cleaning opening

Conical bottom outlet

- Allows complete emptying for efficient cleaning and disinfection

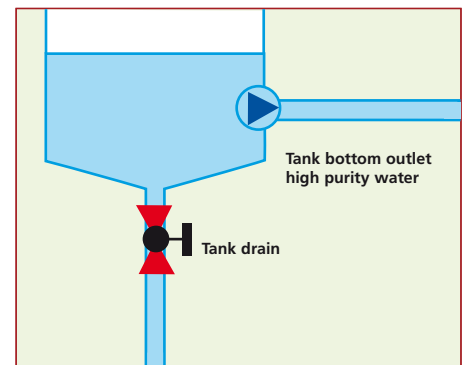

Documentation

TKA LabTower UP/UPW has been developed to fulfill GLP (Good Laboratory Practice) requirements. Recorded and traceable data can be obtained by print out via the RS 232 interface and a TKA printer. Highly qualified and precise measurement of the conductivity is ensured by the cell constant of 0.01 cm^{-1} and the compensation of it, even with minimal changes in temperature, to an accuracy of $\pm 0.1 \text{ }^\circ\text{C}$ (acc. to USP <645>).

Optimal user comfort

Clear information!

The large 4-line display is code-protected and offers a choice of 3 languages; English, German or French. It is illuminated, easily readable and provides information on:

- The temperature in °C
- The temperature compensated conductivity of the water subsequent to the reverse osmosis/high purity water module
- the operating mode status, such as production, stand-by, sanitization
- the tank content in %
- the RS 232 interface
- the fault memory function

Easy to work with!

Just six control keys allow for rapid operational readiness

- Start/stop of high purity water production
- Start/stop of other operating processes and routine maintenance
- Setting the limiting conductivity value for reverse osmosis water and high purity water
- On/off of the optional UV-lamp

Sterile high purity water on call!

Freshly produced high purity water is always there to be taken from the tank or directly from the system. Protected from re-contamination by an optional sterile filter.



Tank level control indicator!

Continual monitoring of the tank volume in %.



A good view!

Just set the tiltable display/keypad unit to the best viewing/operating position for you.



Flow chart for TKA LabTower UP/UPW

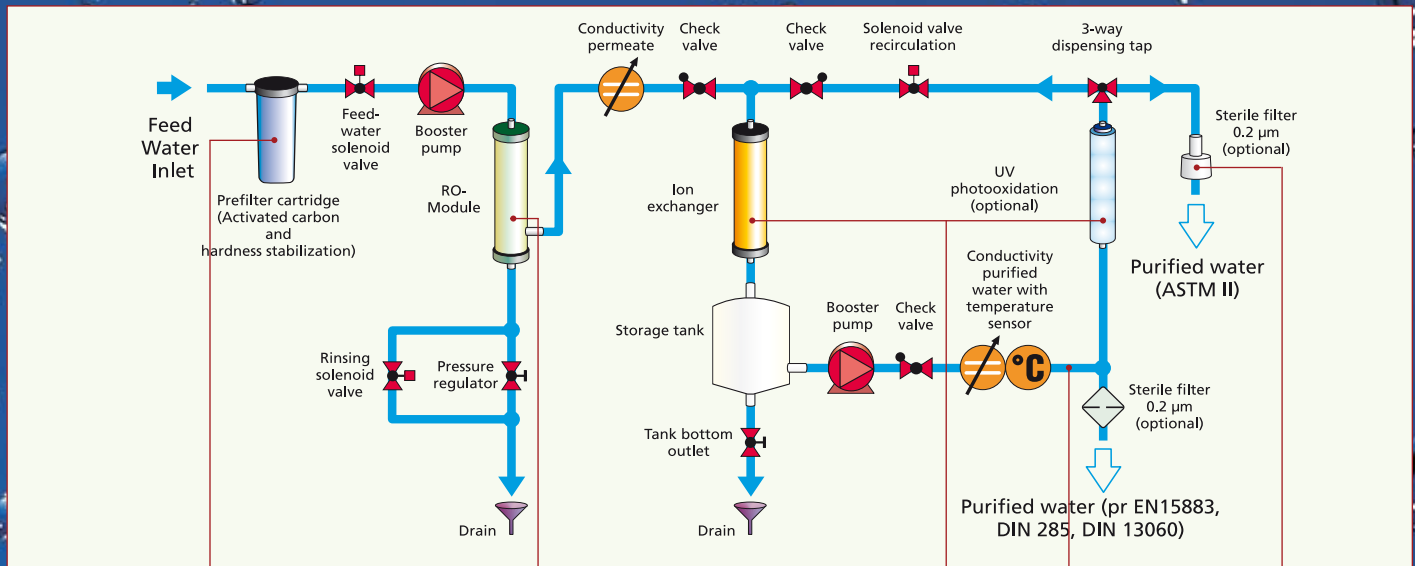

LabTower UP/UPW. High-Tech purification to pure water.

Pretreatment

The 5 µm prefilter and activated carbon in the combi-filter cartridge protect downstream purification stages from free chlorine and particles. The subsequent hardness stabilizing cartridge protects the reverse osmosis stage from hardness forming substances.

TKA can offer further pre-treatment possibilities for unfavourable feedwater conditions on request.

Reverse osmosis and tank

The pretreated water is pressure-forced through the permeable reverse osmosis module, whereby 97 – 99 % of all inorganic ions and 99 % of all dissolved organic substances, as well as microorganisms and particles, are removed from the water.

The built-in 100 l tank has a conical bottom outlet and a suitable lidded opening for easy and efficient cleaning and sanitization.

Ion exchanger/UV

The permeate that emerges from the reverse osmosis module has been purified to 99 %. The very small amounts of cations and anions that are still in the water are now completely removed by passage of it through the TOC tested, high-purity resins in the ion exchange cartridge.

Irradiation with UV light (UPW version only) eliminates any bacteria or germs that are possibly still present. A 1 µm particle removing filter finally brings the optimal result: Water in its purest form.

Dispensing from the front

An additional dispenser at the front of the system itself offers a very convenient dispensing possibility.

Flow rate, 1.5 l/min.
Optionally with an 0.2 µm sterile filter

The result:
H₂O pure – nothing else!
Pure water of type ASTM II that also complies with pr EN15883, DIN EN 285 and DIN 13060 standards

Direct feeding in conformity with the specified standards!

A built-in booster and distribution pump ensures the low-noise purified water supply to downstream units. With a performance of 3 l/min the pump provides both the complete laboratory high purity water supply, e.g. for washing machines and ultrapure water systems, and also the direct feeding to cleaning and disinfection equipment and autoclaves.



■ System components, LabTower UP/UPW

Type LabTower	UP/UPW 20	UP/UPW 40
Flow rate at 15 °C, l/h:	20	40
Typical conductivity in $\mu\text{S}/\text{cm}$:	0.1 – 1	
Typical resistance in $\text{M}\Omega\text{cm}$:	10 – 1	
Bacterial content in CFU/ml, with sterile filter:	< 1	
Particle content (0.2 μm) per ml, with sterile filter:	< 1	
Operating pressure in bar, min./max.:	2/6	
Supply voltage:	230 V/50Hz	
Power consumption in kW:	0.25	
Connector size, male threads:	R 3/4"	
Ambient temperature:	+2 °C – +35 °C	
Dimensions, W x D x H in mm:	450 x 580 x 1500	
Weight in kg:	66	66
Cat. no. UP, 3 l/min pressure pump:	08.4420	08.4440
Cat. no. UPW*, 3 l/min pressure pump:	08.4421	08.4441

* UPW-Version with flow through UV sanitization

TKA feedwater requirements for LabTower UP/UPW systems:

Type of water:	Tap water, max. 1500 ppb
Prefiltration:	5 μm + activated carbon
Free chlorine concentration:	< 0.1 mg/litre
Manganese content:	< 0.05 mg/litre
Iron content:	< 0.05 mg/litre
Colloid index:	< 3
pH-Range:	4 – 11

Accessories

06.5001	Sterile overflow
06.5003	Sterile vent filter, 0.2 μm
06.5006	UV Lamp for the tank
26.0017	UV Lamp for flow-through sanitization
06.5101	prefilter 10", poresize 0.1 μm for tank pure water outlet
09.1003	Sterile filter capsule, 0.2 μm for direct dispensing
16.0129	Leak monitoring with AQUASTOP control and solenoid valve
02.2850-RDS	Ion exchanger, 20 l, replacement cartridge
10.2022	Replacement ion exchanger resin for cartridge 02.2850-RDS, 2 x 22 liters

Replacement disposables

06.5203	Activated carbon cartridge with prefilter 5 μm , for pretreatment
06.5453	Hardnes stabilizer
22.0046	2 x reverse osmosis membrane for LabTower 20 l/h
22.0087	2 x reverse osmosis membrane for LabTower 40 l/h
22.0095	Replacement UV immersion lamp for tank
22.0095	Replacement UV lamp for UP/UPW systems
09.2202	Sanitization kit, pack of 12



TKA Water purification systems

The purification systems for providing laboratory water that are described in this brochure are only part of the comprehensive TKA water purification systems line.

Among others, TKA offers high quality reverse osmosis systems containing state-of-the-art spiral wound membranes, alone or in combination with TKA ion exchangers and electrodeionization modules. Systems for the smallest to the largest need of purified water, for the daily supply of autoclaves up to the production of Aqua Purificata.

We will gladly provide you with further information, advise you on the best choice of pretreatment or recommend an optimal combination of various systems for the performance you require. Always with economy in mind and under consideration of the water quality or qualities that you need. As little as possible, as much as necessary!

It is our aim to offer you water purification systems that provide water of the various qualities as reliably, practically and cost-favourably as possible. Our standard systems are correspondingly designed. Should none of these exactly fit your specific requirements, however, simply contact us! For us, each and every problem is one to be solved. We will find a suitable and economic solution even when conditions are very unfavourable

Your authorized dealer:



TKA Wasseraufbereitungssysteme GmbH
Stockland 3
D-56412 Niederelbert
Telephone: +49 (0) 2602 10699-0
Fax: +49 (0) 2602 10699-50
eMail: info@tka.de
www.tka.de