

Laboratory water purification systems



MD Scientific is an authorized distributor in Denmark
www.md-scientific.dk - +45 7027 8565



adrona

PRODUCT CATALOGUE **2018**



WATER PURIFICATION SYSTEMS

Adrona water purification systems provide ultrapure (Grade 1), pure (Grade 2) and reverse osmosis (RO) water for laboratory needs. The quality of water meets the requirements of ISO 3696 standard and corresponding ASTM and CLSI standards.

Tap water systems	Water type
Q-Front EDI	Ultrapure/pure
B30	Ultrapure/pure
Integrity +	Ultrapure
E30	Ultrapure/pure
Crystal EX	Ultrapure/pure/RO ¹
Crystal Clinic	Pure
Crystal Sterifeed	RO

Polishing systems	Water type
Onsite +	Ultrapure
Connect	Ultrapure

¹ depending on model, water purification systems can produce ultrapure and pure water or RO and pure water

CONFIGURATIONS ACCORDING TO APPLICATIONS

Each Adrona model is available in various configurations according to the customer needs

Applications	RO	Pure	EDI	Trace	HPLC	Bio
General laboratory applications	Glassware rinsing	•	•	•	•	•
	Laboratory washers	•	•	•	•	•
	Autoclaves	•	•	•	•	•
	Electrochemistry		•	•	•	•
	Wet chemistry		•	•	•	•
	Spectrophotometry		•	•	•	•
	Buffer and media preparation		•	•	•	•
	Reagent preparation			•	•	•
Inorganic analysis methods	Flame atomic absorption spectrophotometry			•	•	•
	Graphite automizer atomic absorption spectrophotometry				•	•
	Plasma mass-spectrometry (ICP-MS)				•	•
	Plasma spectrophotometry (ICP-OES)				•	•
	Ion chromatography				•	•
Organic analysis methods	Liquid chromatography (HPLC/UHPLC)				•	•
	Gas chromatography				•	•
	Total organic carbon measurements				•	•
Molecular Biology	Flow cytometry					•
	Cell and tissue culture					•
	Molecular biology					•

FEATURES

The systems are installable by user and all cartridges and filters are user replaceable. ANDROTOOL is recommended to use for cartridge replacement. All necessary consumables are installed into the water system and they are included in price.

Adrona water purification systems can be installed either on a laboratory bench or on a wall¹. Wallmount installation provides the saving of valuable laboratory space.

VOLUMETRIC DISPENSE

Adrona water purification systems² have a volumetric dispenser, which enables the user to set accurate dispensing volume for each dispense cycle. The dispense volume can be set either from the keyboard or by using “teaching” mode. In “teaching” mode user uses “Dispense On/OFF” button to do the first dispense cycle manually. Afterwards, the system will dispense exactly the same volume each time the user presses the dispense button again.

WATER QUALITY AND VALIDATION

Embedded recirculation loop ensures stable premium water quality and enables practical elimination of Total Organic Carbon (TOC).

Performance of the deionization and polishing modules is constantly monitored. Monitoring algorithm enables cutting running costs, as replacement of the modules is requested only when service life is close to the end.

Stability of water quality guaranteed by double Ion Exchange cartridge system². (Adrona systems have 2 Ion Exchange cartridges (deionization and polishing) therefore excellent water quality guaranteed even if one of them is waiting for replacement at the moment).

User can carry out the validation of water quality sensors right on the site (available on B30, Integrity+, Connect and Onsite+). It is possible to validate conductivity measuring circuits to check if they are operating properly. Validation dongle for OQ is available as an option. This helps the customer to validate water quality measuring circuits on periodical basis. No visit of service engineer is required.

For the complete conductivity sensor test external portable conductometer with flow cell can be used.

TOTAL ORGANIC CARBON (TOC) MONITOR

Organic contaminants may not have effect on conductivity of water, so conductivity sensors cannot be used for TOC monitoring. Therefore, a special TOC monitoring module is needed to measure TOC level. Several models of Adrona water purification systems have the TOC monitor feature. TOC values are shown on display.

DISPLAYS

Provides clear water quality readout and information about the system status including current resistivity and remaining pre-filter service life.

MONOCHROME HIGH RESOLUTION LCD DISPLAY



COLOR GRAPHIC LCD DISPLAY

The 16-bit color display provides clear readout of water quality, system component status, performance of the polishing module. System component status is reflected on the display in an intuitive color pattern (Green/Yellow/Red).

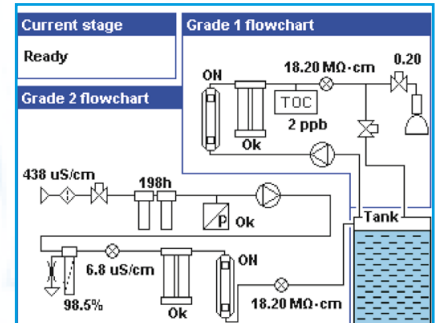

System flowchart shows all component status and water quality parameters at a glance.

Image can vary depending on model and its configuration.

ELECTRODEIONIZATION MODULE

For the laboratories with the high water consumption Adrona offers Q Front EDI or RADIX systems. It allows significantly reduce the running costs of water purification system due to fact the replacement of EDI module is not required anymore.

SAFETY

All the Adrona water purification systems have all necessary safety functions. They are tested by an independent and accredited company for compliance with the CE directives related to safety and electromagnetic compatibility.

WARRANTY AND AFTERSALES

SUPPORT

Adrona provides 2 year warranty and continuous technical support. Adrona support is evaluated very positively by dealers worldwide.

CERTIFICATION

Adrona design, manufacturing, sales and service is ISO 9001:2015 certified to provide the highest quality in every aspect.

¹ If not specified otherwise

² Depends on model and configuration



B30 AND INTEGRITY+

The high-end B30 and Integrity+ series water purification systems produce ultrapure and pure water for laboratory needs.

B30 model have to be configured with external tank with capacity of 30 L or 60 L. Integrity+ series systems contain a 5 L

embedded tank to keep the system compact.

DESCRIPTION

	B30 Trace	B30 HPLC	B30 Bio
Water type	<ul style="list-style-type: none"> • ultrapure water (Grade 1) • pure water (Grade 2) 	<ul style="list-style-type: none"> • ultrapure water (Grade 1) • pure water (Grade 2) 	<ul style="list-style-type: none"> • ultrapure water (Grade 1) • pure water (Grade 2)
Application	<ul style="list-style-type: none"> • atomic absorption spectrometry • plasma optical emission spectrometry • other inorganic trace analysis 	<ul style="list-style-type: none"> • chromatography • mass spectrometry • microbiology • molecular biology 	<ul style="list-style-type: none"> • highly sensitive molecular biology • cell culture • other methods sensitive to RNase and endotoxins • biology applications
Display	color graphic LCD display		
Water quality sensor	•	•	•
TOC Monitor	-	•	•
Measurement validation port	•	•	•
Volumetric dispense	•	•	•
Connection possibility to Flow Point	•	•	•
Storage tank	required but not included		
Installation	installable either on a laboratory bench or on a wall		

DESCRIPTION

	Integrity+ Trace	Integrity+ HPLC	Integrity+ Bio
Water type	ultrapure water (Grade 1)	ultrapure water (Grade 1)	ultrapure water (Grade 1)
Application	<ul style="list-style-type: none"> • atomic absorption spectrometry • plasma optical emission spectrometry • other inorganic trace analysis 	<ul style="list-style-type: none"> • chromatography • mass spectrometry • microbiology • molecular biology 	highly sensitive biology applications
Display	Color graphic LCD display		
Conductivity sensor	•	•	•
TOC Monitor	-	•	•
Measurement validation port	•	•	•
Volumetric dispensing	•	•	•
Connection possibility to Flow Point	•	•	•
Storage tank	embedded tank 5L		
Installation	installable either on a laboratory bench or on a wall		

ORDERING INFORMATION

Model	Part number
B30 Trace	CB-2301
B30 HPLC	CB-2303
B30 Bio	CB-2305
Integrity+ Trace	CB-2101
Integrity+ HPLC	CB-2103
Integrity+ Bio	CB-2105
Water quality sensor validation dongle	10913
IQ/OQ documentation	10141

SPECIFICATIONS

Purified water parameters	B30/Integrity+ system configuration		
	Trace	HPLC	Bio
Grade 1 water resistivity	18.2 MΩ x cm	18.2 MΩ x cm	18.2 MΩ x cm
Grade 1 water conductivity	0.055 μS/cm	0.055 μS/cm	0.055 μS/cm
Grade 2 water conductivity	0.1 μS/cm	0.1 μS/cm	0.1 μS/cm
Total Organic Carbon (TOC) level	<10 ppb	<2 ppb	<2 ppb
RNase	-	-	<0.01 ng/mL
DNase	-	-	<4 pg/μL
Bacteria	< 1 CFU/mL	< 1 CFU/mL	< 0.1 CFU /mL
Endotoxins	<0.15 EU /mL	<0.15 EU /mL	< 0.001 EU /mL
Particles >0.22 μm	<1/mL	<1/mL	<1/mL
Deionization module life*	1 m ³	1 m ³	1 m ³
Dimensions (WxDxH), cm	32x56x62	32x56x62	32x56x62
Weight, kg	24	25	26
Data interface	RS 232	RS 232	RS 232
Feed water pressure	0,5 – 4 bar* 2 – 6 bar**	0,5 – 4 bar* 2 – 6 bar**	0,5 – 4 bar* 2 – 6 bar**

* B30 ** Integrity+

CONSUMABLES

Part number	Description	Replacement criteria	Comments
10310	Deionization module	When indicated on the display or water conductivity is constantly > 0.5 μS/cm during tank filling stage	
10030	Polishing module "Polishing+"	When indicated on the display or water conductivity is constantly > 0.1 μS/cm during recirculation	
10319	Pre-filter set	Filter life counter is zero or the filter is clogged	
10018	UV photooxidation bulb	2 years on average	Only for „Bio” and „HPLC”
10012	Point-of-use microfilter	Every 6–12 months	Only for „Trace” and „HPLC”
10120	Point-of-use ultrafilter	Every 3–6 months	Only for „Bio”
10011	UV sterilization bulb	When required (on average every 2 years)	Only for „Bio”

FLOW DIAGRAM

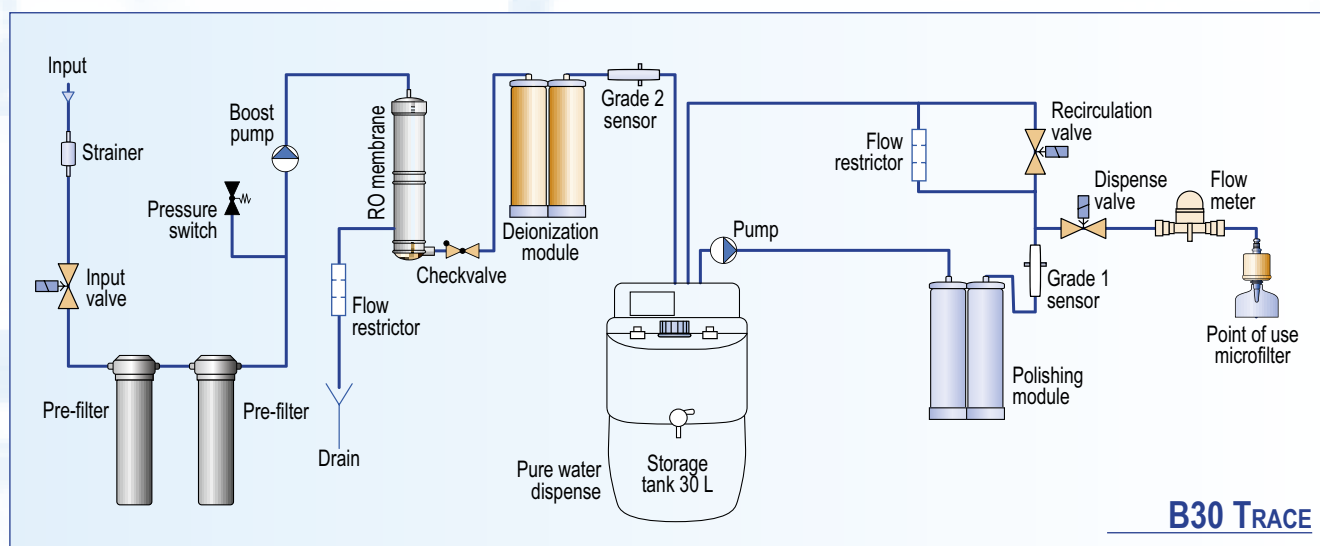

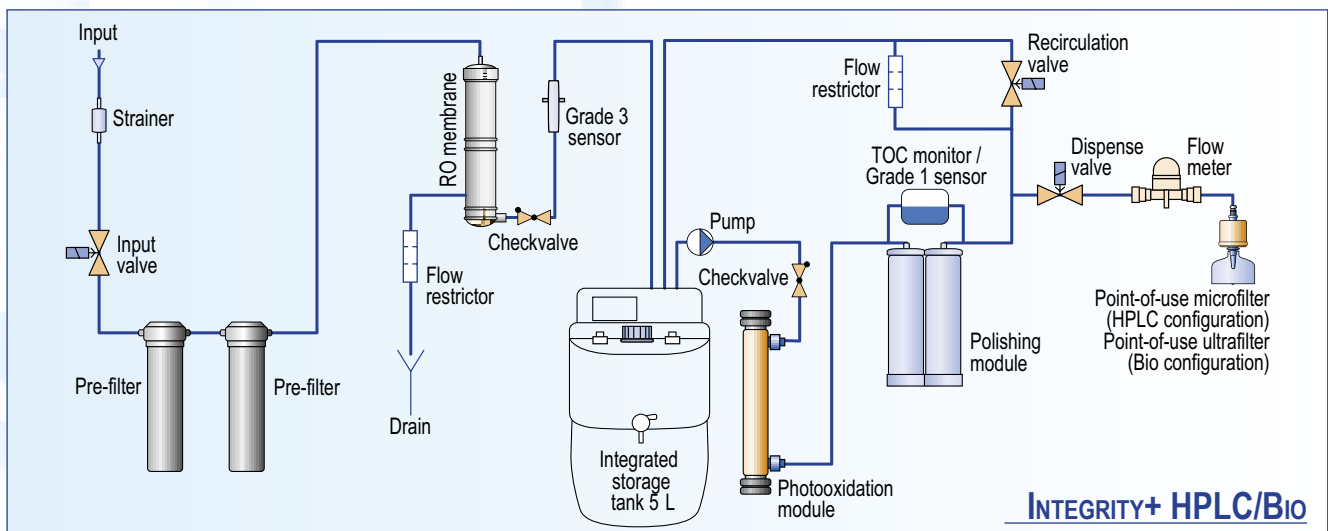
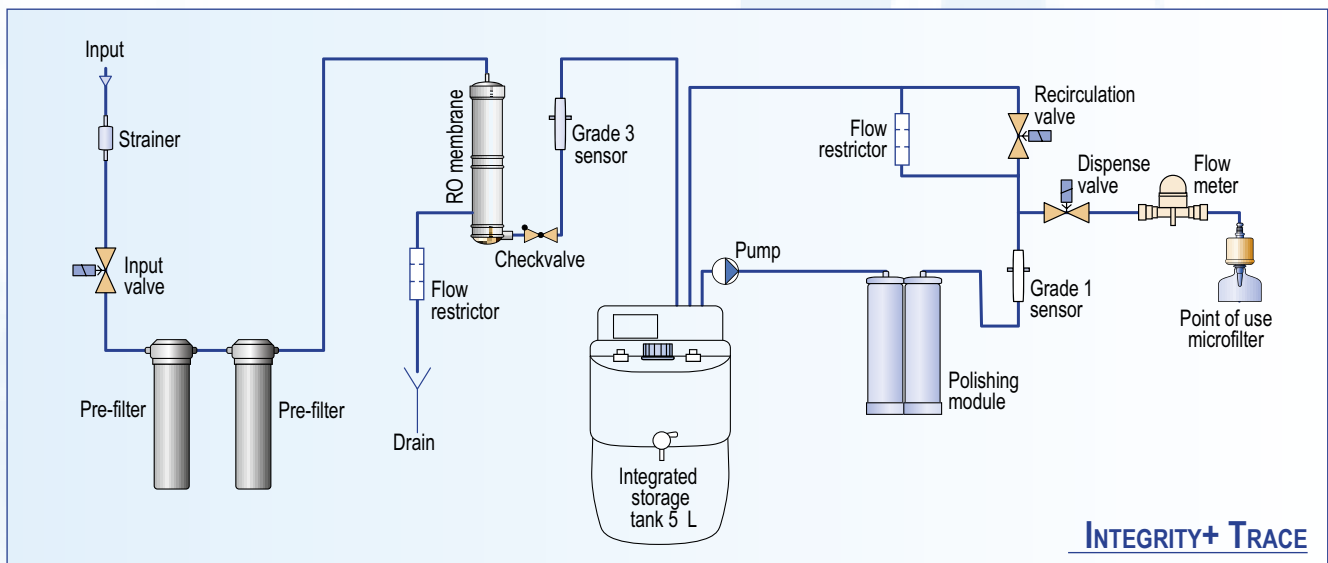
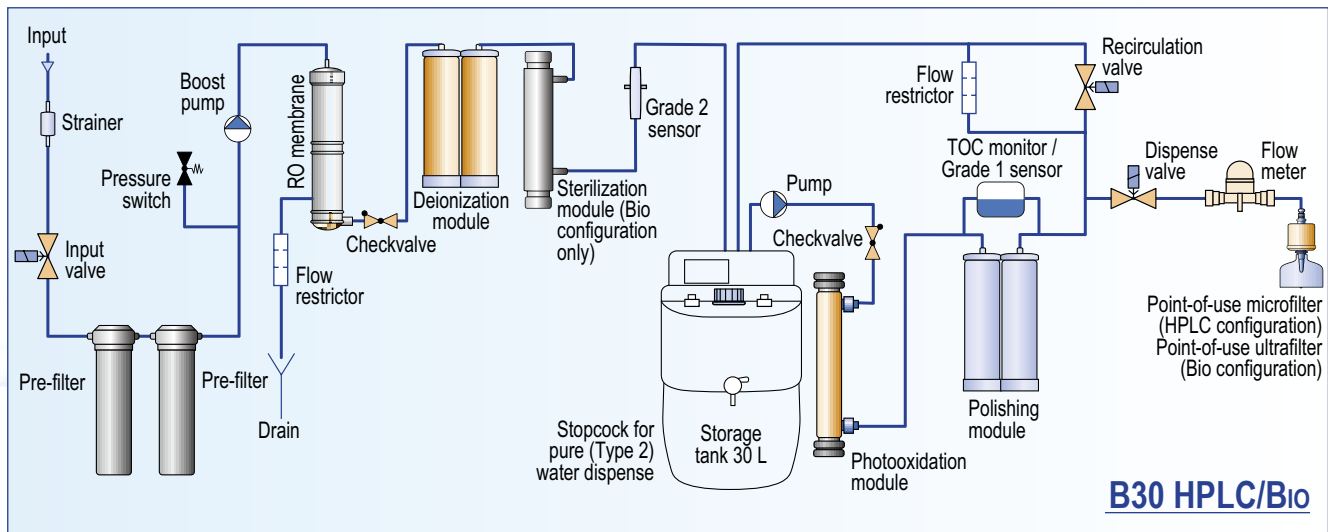

Q-FRONT



The newest pure and ultrapure water system with maximum features, convenience and performance. This is the essence of know-hows and experience of Adrona engineers obtained during the decades. Choose between 3 configurations to fit all specific laboratory needs.

- New prefilter with significantly higher trapping capability
- Improved RO and deioniser lifetime
- Stable output water quality
- Convenient flexible dispenser
- Sanitisation cartridge available
- Configuration with EDI or conventional deionisation

DESCRIPTION

	Q-Front EDI Trace	Q-Front EDI HPLC	Q-Front EDI Bio
Water type	<ul style="list-style-type: none"> • ultrapure water (Grade 1) • pure water (Grade 2) 	<ul style="list-style-type: none"> • ultrapure water (Grade 1) • pure water (Grade 2) 	<ul style="list-style-type: none"> • ultrapure water (Grade 1) • pure water (Grade 2)
Application	<ul style="list-style-type: none"> • atomic absorption spectrometry • plasma optical emission spectrometry • other inorganic trace analysis 	<ul style="list-style-type: none"> • chromatography • mass spectrometry • microbiology • molecular biology 	<ul style="list-style-type: none"> • highly sensitive molecular biology • cell culture • other methods sensitive to RNase and endotoxins • biology applications
Display	color graphic LCD display		
Water quality sensor	•	•	•
TOC Monitor	-	•	•
Measurement validation port	•	•	•
Volumetric dispense	•	•	•
Dispenser	Attached flexible dispenser	Attached flexible dispenser	Attached flexible dispenser
Storage tank	tank "Pro" 30 L included, other tanks optional		
Installation	installable on a laboratory bench		



SPECIFICATIONS

Purified water parameters	Q-Front system configuration		
	Trace	HPLC	Bio
Grade 1 water resistivity	18.2 MΩ x cm	18.2 MΩ x cm	18.2 MΩ x cm
Grade 1 water conductivity	0.055 μS/cm	0.055 μS/cm	0.055 μS/cm
Grade 2 water conductivity	0.1 μS/cm	0.1 μS/cm	0.1 μS/cm
Total Organic Carbon (TOC) level	<10 ppb	<2 ppb	<2 ppb
RNase	-	-	<0.01 ng/mL
DNase	-	-	<4 pg/μL
Bacteria	< 1 CFU/mL	< 1 CFU/mL	< 0.1 CFU /mL
Endotoxins	<0.15 EU /mL	<0.15 EU /mL	< 0.001 EU /mL
Particles >0.22 μm	<1/mL	<1/mL	<1/mL
Deionization module life*	1 m ³ *	1 m ³ *	1 m ³ *
Feed water pressure	0,5 – 4 bar	0,5 – 4 bar	0,5 – 4 bar
Data interface	RS 232	RS 232	RS 232
Dimensions (WxDxH), cm	35x39x54	35x39x54	35x39x54
Weight, kg	27	28	29

ORDERING INFORMATION

Model	Part number
Part number depends on the configuration	See Price List for further information
Water quality sensor validation kit	10913
IQ/OQ documentation	10142

* Q-Front EDI electrodeionization module life is not limited as it is regenerated automatically

CONSUMABLES

Part number	Description	Replacement criteria	Comments
10310	Deionization module	When indicated on the display or water conductivity is constantly > 0.1 μS/cm during tank filling stage	
10030	Polishing module "Polishing+"	When indicated on the display or water conductivity is constantly > 0.1 μS/cm during recirculation	
10410	Pre-filter set	Filter life counter is zero or the filter is clogged	
10018	UV photooxidation bulb	2 years on average	Only for „Bio” and „HPLC”
10012	Point-of-use microfilter	Every 6–12 months	Only for „Trace” and „HPLC”
10120	Point-of-use ultrafilter	Every 3–6 months	Only for „Bio”
10011	UV sterilization bulb	When required (on average every 2 years)	Only for „Bio”

FLOW DIAGRAM

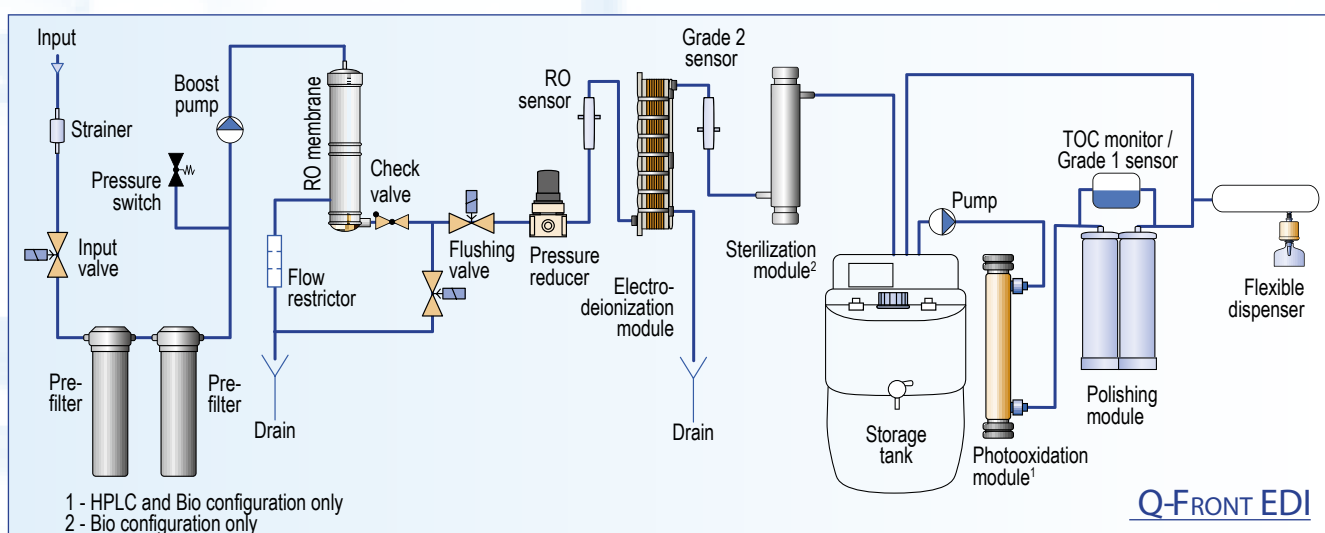

E30

E30 water purification system produce ultrapure and pure water for laboratory needs. It is designed for maximum convenience of use and have maximum features. This system is with high price/performance ratio.

ORDERING INFORMATION

Model	Part number
E30 Trace	CE30-1001
E30 HPLC	CE30-1101
E30 Bio	CE30-1201



DESCRIPTION

	E30 Trace	E30 HPLC	E30 Bio
Water type	<ul style="list-style-type: none"> ultrapure water (Grade 1) pure water (Grade 2) 	<ul style="list-style-type: none"> ultrapure water (Grade 1) pure water (Grade 2) 	<ul style="list-style-type: none"> ultrapure water (Grade 1) pure water (Grade 2)
Application	<ul style="list-style-type: none"> atomic absorption spectrometry plasma optical emission spectrometry other inorganic trace analysis 	<ul style="list-style-type: none"> chromatography mass spectrometry microbiology molecular biology 	highly sensitive biology applications
Display	Color LCD display		
Conductivity sensor	•	•	•
TOC Monitor	-	•	•
Measurement validation port	-	-	-
Volumetric dispensing	•	•	•
Connection possibility to Flow Point	•	•	•
Storage tank	required but not included		
Installation	installable on a laboratory bench		

SPECIFICATIONS

Purified water specifications	E30 Trace	E30 HPLC	E30 Bio
Grade 1 water resistivity	18.2 MΩ x cm	18.2 MΩ x cm	18.2 MΩ x cm
Grade 1 water conductivity	0.055 μS/cm	0.055 μS/cm	0.055 μS/cm
Grade 2 water conductivity	<0.1 μS/cm	<0.1 μS/cm	<0.1 μS/cm
Total Organic Carbon (TOC) level	<10 ppb	<2 ppb	<2 ppb
RNase	N/A	N/A	<0.01 ng/mL
DNase	N/A	N/A	<4 pg/μL
Bacteria	< 1 CFU/mL	< 1 CFU/mL	< 0.1 CFU/mL
Endotoxins	<0.15 EU/mL	<0.15 EU/mL	< 0.001 EU/mL
Particles >0.22 μm	<1 per mL	<1 per mL	<1 per mL
Nominal flow, pure water (to storage tank)	10 L/h	10 L/h	10 L/h
Deionization module life (standard module)	1 m ³	1 m ³	1 m ³
Recovery	>30 %	>30 %	>30 %
Dimensions (WxDxH), cm	40x35x55	40x35x55	40x35x55
Weight, kg	17	18	19
Feed water pressure	0,5 – 4 bar	0,5 – 4 bar	0,5 – 4 bar
Feed water conductivity	< 1500 μS/cm	< 1500 μS/cm	< 1500 μS/cm

CONSUMABLES

Part number	Description	Replacement criteria	Comments
10320	Replacement pre-filter, E30	Filter life counter is zero or the filter is clogged	
10310	Replacement deionization module	„DI Err” message is shown, or water conductivity is consistently > 0.5 $\mu\text{S}/\text{cm}$	
10029	Replacement polishing module	Every 1–2 years, depending on operation	
10030	Polishing module “Polishing+”	Every 1–2 years, depending on operation	
10011	Replacement sterilization UV bulb	When required (on average every 2 years)	„Bio” systems only
10018	Replacement photooxidation UV bulb	2 years on average	„HPLC” and „Bio” systems only
10012	Replacement 0.22 μm dispense microfilter	Every 6–12 months	„Trace” and „HPLC” systems
10120	Replacement ultrafilter	Every 3–6 months	„Bio” systems only

FLOW DIAGRAMS

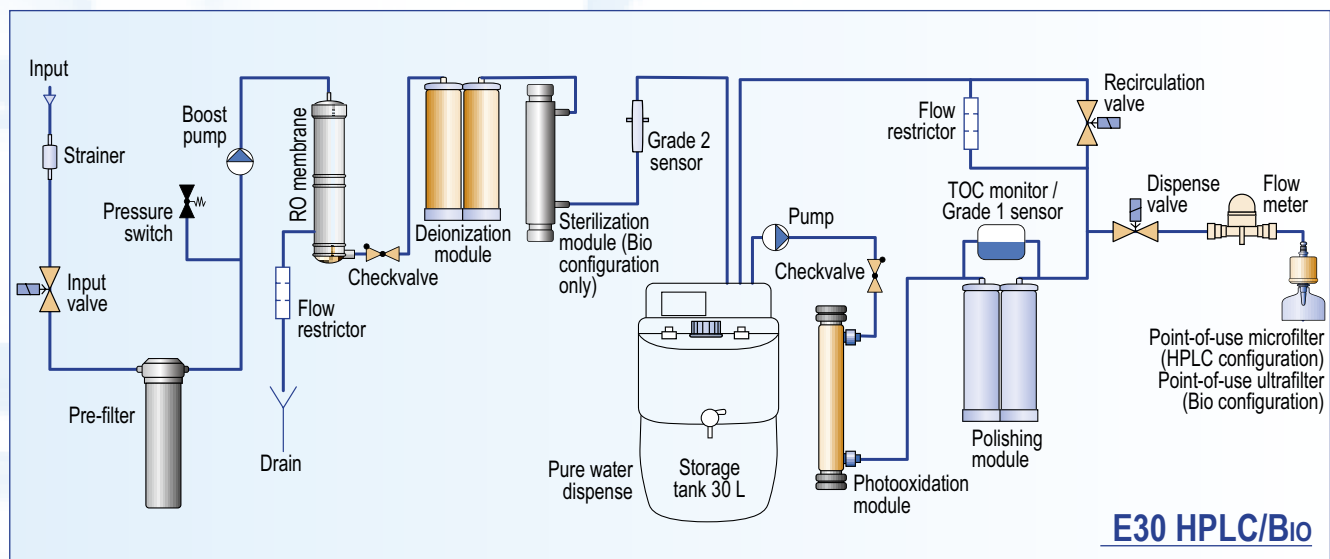
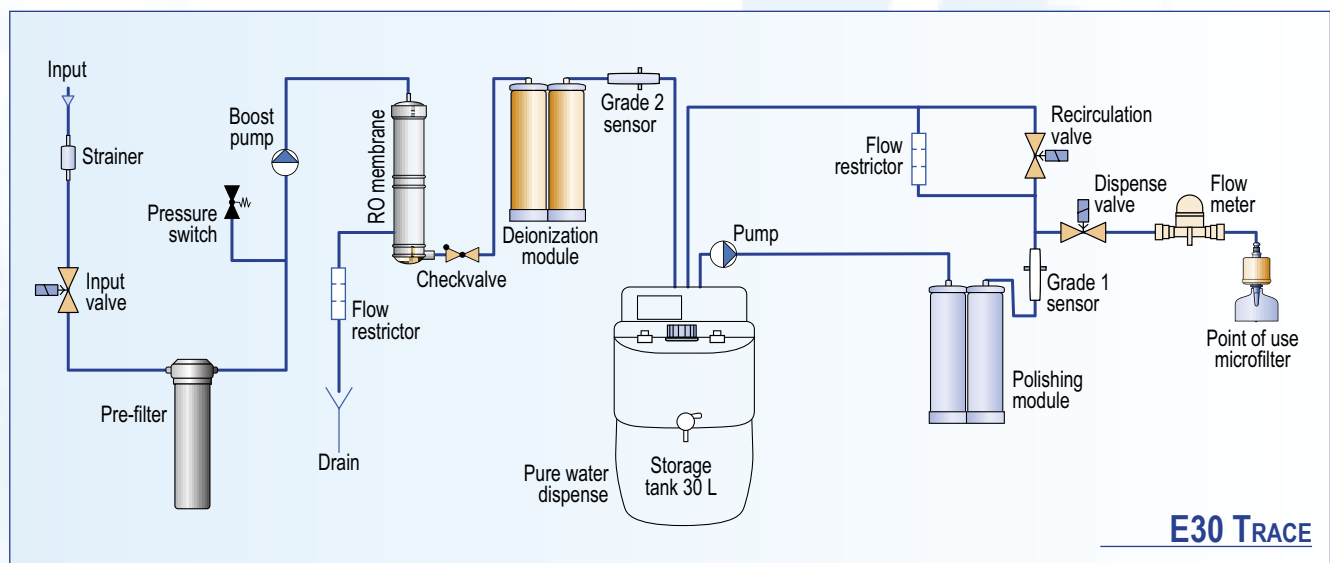

CRYSTAL EX

Adrona Crystal EX produces ultrapure and pure water. This multipurpose water purification system is highly appreciated due to the very affordable price.



ORDERING INFORMATION

Model	Part number
Crystal EX Trace	EX-1001
Crystal EX HPLC	EX-1101
Crystal EX Bio	EX-1201

DESCRIPTION EX SERIES

	Trace	HPLC	Bio
Water type	<ul style="list-style-type: none"> ultrapure water (Grade 1) pure water (Grade 2) 	<ul style="list-style-type: none"> ultrapure water (Grade 1) pure water (Grade 2) 	<ul style="list-style-type: none"> ultrapure water (Grade 1) pure water (Grade 2)
Application	<ul style="list-style-type: none"> atomic absorption spectrometry plasma optical emission spectrometry other inorganic trace analysis 	<ul style="list-style-type: none"> chromatography mass spectrometry microbiology molecular biology 	highly sensitive biology applications
Display	Monochrome LCD display		
Conductivity sensor	•	•	•
TOC Monitor	-	-	-
Measurement validation port	-	-	-
Volumetric dispensing	-	-	-
Connection possibility to Flow Point	No	No	No
Storage tank	required but not included		
Installation	installable on a laboratory bench		

SPECIFICATIONS

Purified water specifications	Crystal EX Trace	Crystal EX HPLC	Crystal EX Bio
Grade 1 water resistivity	18.2 MΩ x cm	18.2 MΩ x cm	18.2 MΩ x cm
Grade 1 water conductivity	0.055 μS/cm	0.055 μS/cm	0.055 μS/cm
Grade 2 water resistivity	>10 MΩ x cm	>10 MΩ x cm	>10 MΩ x cm
Grade 2 water conductivity	<0.1 μS/cm	<0.1 μS/cm	<0.1 μS/cm
Total Organic Carbon (TOC) level	<10 ppb	<2 ppb	<2 ppb
RNase	N/A	N/A	<0.01 ng/mL
DNase	N/A	N/A	<4 pg/μL
Bacteria	< 1 CFU/mL	< 1 CFU/mL	< 0.1 CFU/mL
Endotoxins	<0.15 EU/mL	<0.15 EU/mL	< 0.001 EU/mL
Particles >0.22 μm	<1 per mL	<1 per mL	<1 per mL
Nominal flow, pure water (to storage tank)	10 L/h	10 L/h	10 L/h
Deionization module life (standard module)	1 m ³	1 m ³	1 m ³
Deionization module life (high capacity module)	3 m ³	3 m ³	3 m ³
Recovery	>30 %	>30 %	>30 %
Dimensions (WxDxH), cm	40x35x55	40x35x55	40x35x55
Weight, kg	17	18	19
Feed water pressure	0.5 – 4 bar	0.5 – 4 bar	0.5 – 4 bar
Feed water conductivity	< 1500 μS/cm	< 1500 μS/cm	< 1500 μS/cm

CONSUMABLES

Part number	Description	Replacement criteria	Comments
10320	Replacement pre-filter, Crystal EX	Filter life counter is zero or the filter is clogged	
10310	Replacement deionization module	„DI Err” message is shown, or water conductivity is consistently > 0.5 μS/cm	
10029	Replacement polishing module	Every 1–2 years, depending on operation	
10030	Polishing module “Polishing+”	Every 1–2 years, depending on operation	
10011	Replacement sterilization UV bulb	When required (on average every 2 years)	„Bio” systems only
10018	Replacement photooxidation UV bulb	2 years on average	„HPLC” and „Bio” systems only
10012	Replacement 0.22 μm dispense microfilter	Every 6–12 months	„Trace” and „HPLC” systems
10120	Replacement ultrafilter	Every 3–6 months	„Bio” systems only

FLOW DIAGRAMS

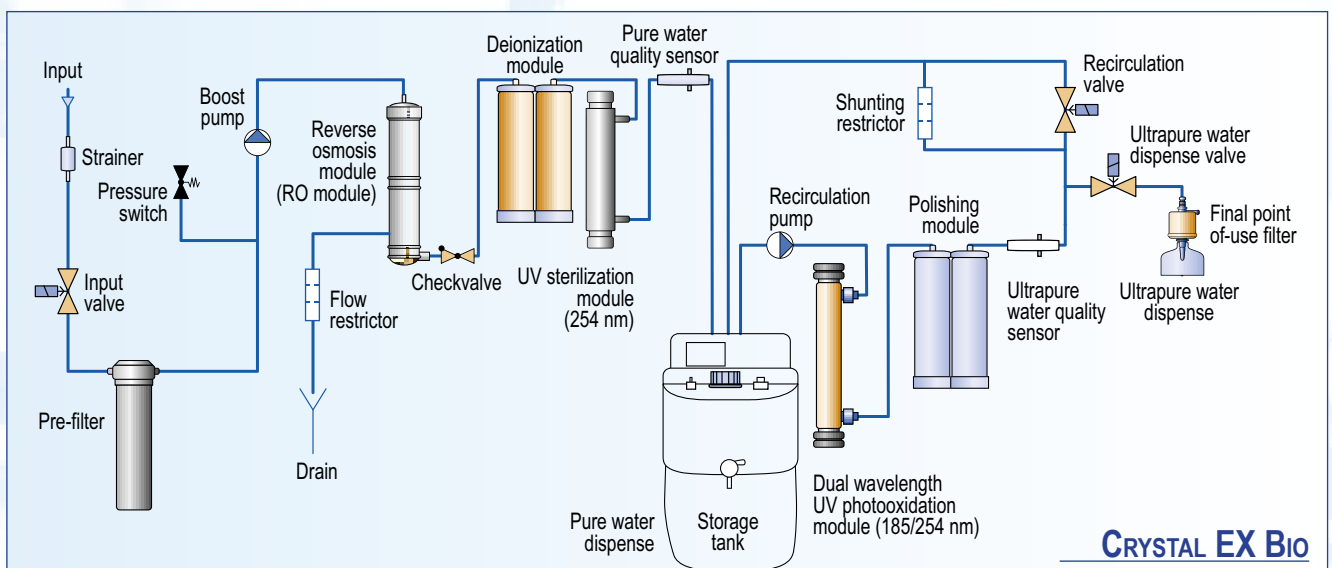
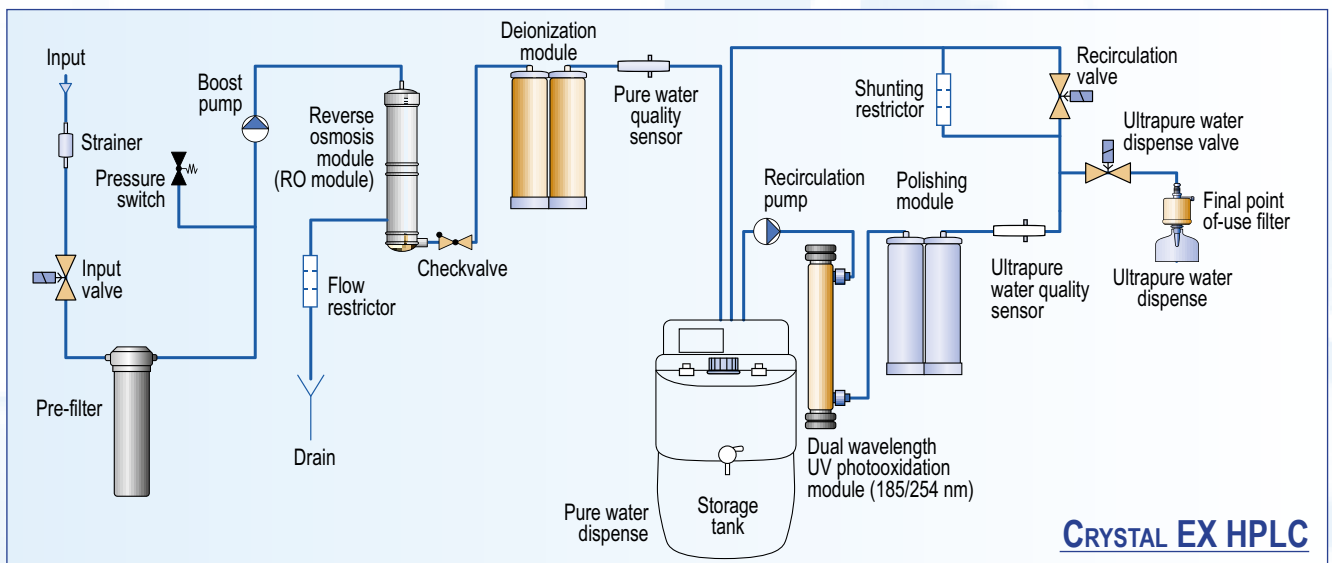
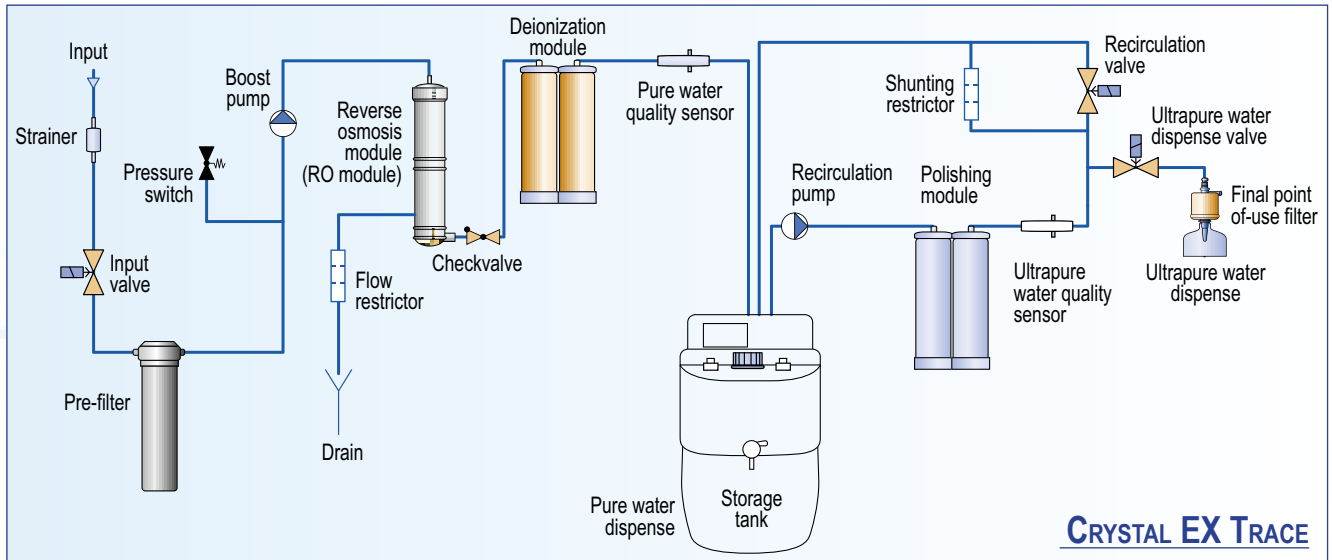



CRYSTAL EX PURE CRYSTAL EX DOUBLE FLOW CRYSTAL EX RO

Crystal EX RO and Pure systems produce pure (Grade 2) and RO (Grade 3) water. Pure and RO water comply with the requirements of a variety of applications, including:

- many inorganic methods of analysis (e. g. flame AAS);
- wet chemistry methods;
- electrochemistry;
- labware washing, etc.

The water purification system Crystal Double Flow is specially designed for the laboratories and applications with high water consumption (30 L/day and more). The system includes a high capacity (8L) deionization module, that provides a reduction of system running costs.

DESCRIPTION

	Crystal EX RO	Crystal EX Pure	Crystal EX Double Flow
Water type	RO water	pure water (Grade 2)	pure water (Grade 2)
Application	<ul style="list-style-type: none"> • wet chemistry methods • labware washing • steam sterilizers • polishers feed 	<ul style="list-style-type: none"> • flame spectrophotometry • inorganic analytical methods • electrochemistry • buffer preparation 	<ul style="list-style-type: none"> • flame spectrophotometry • inorganic analytical methods • electrochemistry • buffer preparation
Display	Monochrome LCD display		
Conductivity sensor	•	•	•
TOC Monitor	-	-	-
Measurement validation port	-	-	-
Volumetric dispensing	-	-	-
Connection to Flow Point	No	No	No
Storage tank	30 – 300 L		
Installation	installable on a laboratory bench		

ORDERING INFORMATION

Model	Part number
Crystal EX RO	EX-1245
Crystal EX Pure	EX-1005
Crystal EX Double Flow	EX20-1001HC
Crystal EX Double Flow with 10410 prefilter	EX20-1002HC

SPECIFICATIONS

Purified water specifications	Crystal EX RO	Crystal EX Pure	Crystal EX Double Flow
Purified water resistivity		>10 MΩ x cm	>10 MΩ x cm
Purified water conductivity	TDS rejection rate >98%	<0.1 μS/cm	<0.1 μS/cm
Particles >0.22 μm	<1 per mL	<1 per mL	<1 per mL
Nominal flow, pure water (to storage tank)	10 L/h	10 L/h	20 L/h
Deionization module life (standard module)	N/A	1 m ³	N/A
Deionization module life (high capacity module)	N/A	N/A	3 m ³
Recovery	>30 %	>30 %	>30 %
Dimensions (WxDxH), cm	40x35x55	40x35x55	40x50x55
Weight, kg	10	12	26
Feed water pressure	0.5 – 4 bar	0.5 – 4 bar	0.5 – 4 bar
Feed water conductivity	< 1500 μS/cm	< 1500 μS/cm	< 1500 μS/cm

CONSUMABLES

Part number	Description	Replacement criteria	Comments
10320	Replacement pre-filter, Crystal EX RO, Pure	Filter life counter is zero or the filter is clogged	
10319	Replacement pre-filter set, Crystal EX Double Flow	Filter life counter is zero or the filter is clogged	
10310	Replacement deionization module	„DI Err” message is shown, or water conductivity is consistently > 0.5 μS/cm	“Pure” systems only
10113	Replacement high-capacity deionization module	„DI Err” message is shown, or water conductivity is consistently > 0.5 μS/cm	Only “EX Double Flow”
10011	Replacement sterilization UV bulb	As required (on average every 2 years)	Only systems with 10102 option
10410	Prefilter for EX20-1002HC	Filter life counter is zero or the filter is clogged	

FLOW DIAGRAMS

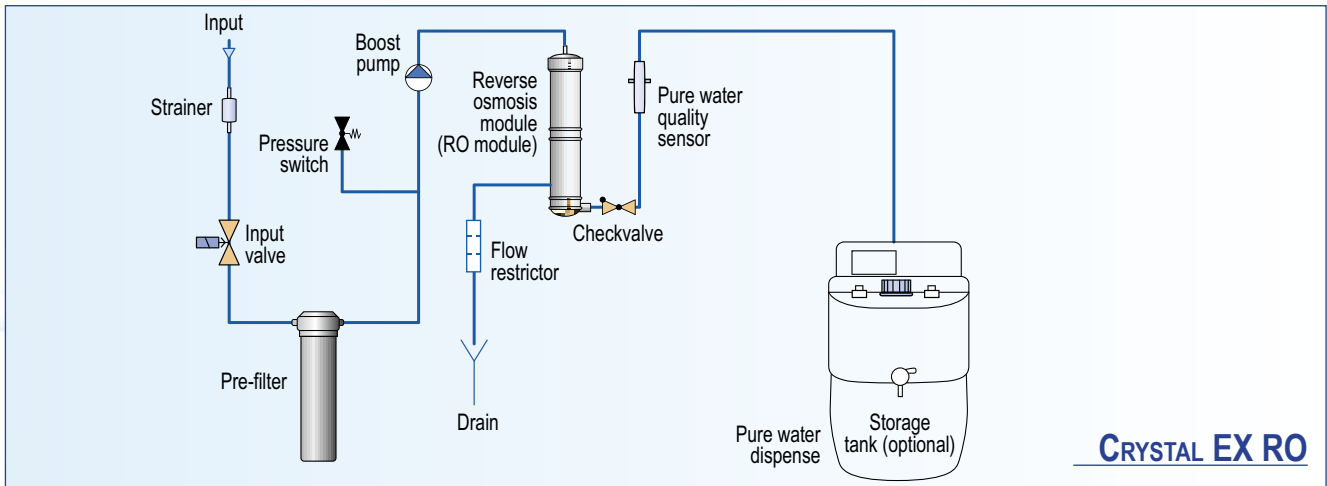

CRYSTAL EX RO

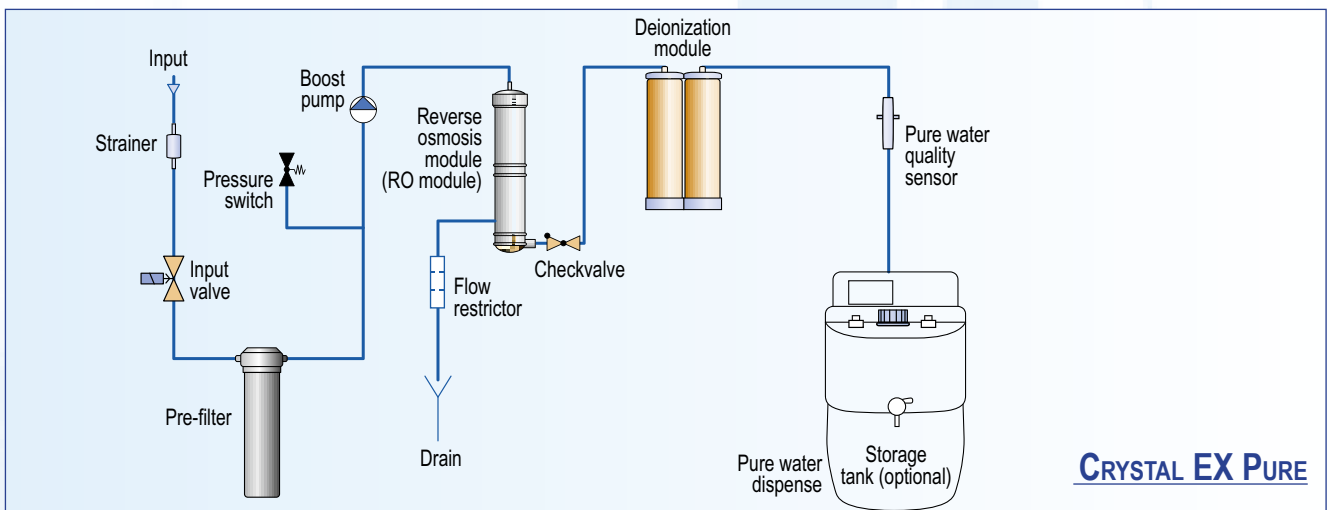

CRYSTAL EX PURE

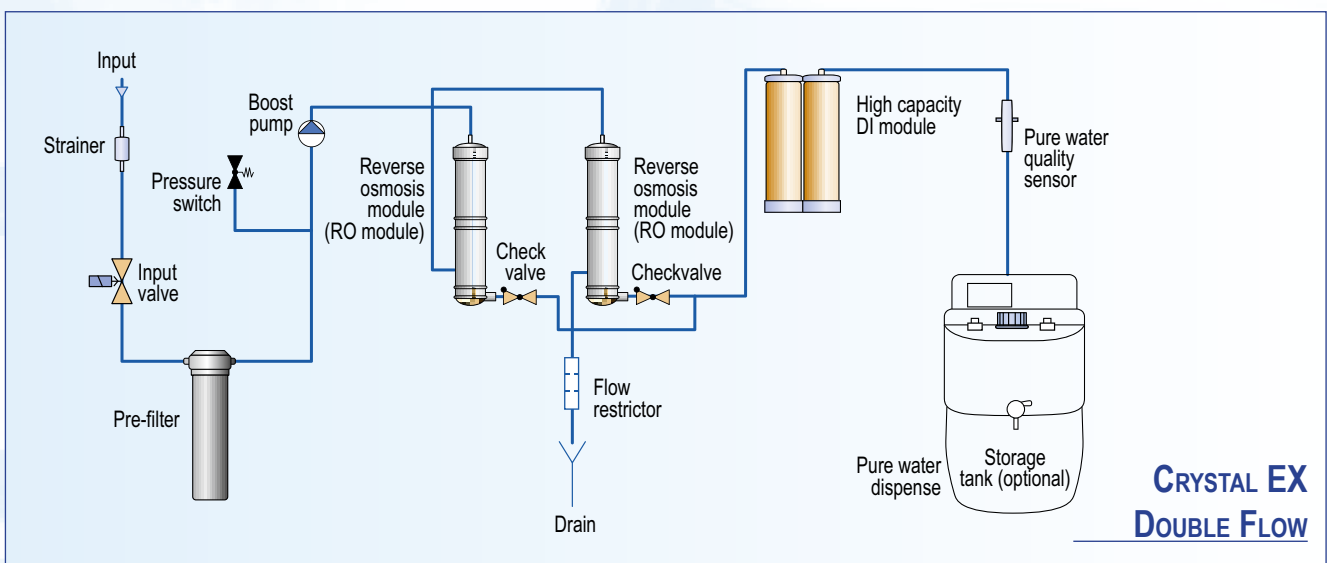

**CRYSTAL EX
DOUBLE FLOW**

CRYSTAL CLINIC

The Crystal Clinic water purification system is designed to provide purified water for smooth and reliable operation of automated biochemistry analyzers.

Crystal Clinic has two reverse osmosis modules and high capacity deionization cartridge (DI). Large DI cartridge volume significantly reduces running costs.

Crystal Clinic has two water quality sensors. The first sensor controls quality of water filling the storage tank that is shown on the display while the tank is being filled. The second sensor controls quality of water supplied to a biochemical analyzer.



DESCRIPTION

Water type	pure water (Grade 2)
Application	purified water for automated biochemistry analyzers
Display	monochrome LCD display
Conductivity sensor	•
TOC Monitor	-
Measurement validation port	-
Volumetric dispensing	-
Connection to Flow Point	-
Storage tank	pressurized storage tank, 100 L
Installation	installable on a laboratory bench

ORDERING INFORMATION

Model	Part number
Crystal Clinic	CL-2910

SPECIFICATIONS

Purified water specifications	Crystal Clinic
Grade 2 water resistivity	>10 MΩ x cm
Grade 2 water conductivity	<0.1 μS/cm
Particles >0.22 μm	<1 per mL
Nominal flow, pure water (to storage tank)	20 L/h
Dispense flow to analyzer	4 L/min
Dispense pressure (adjustable)	100 - 180 kPa
Deionization module life (high capacity module)	3 m ³
Recovery	>30 %
Dimensions (WxDxH), cm	40x34x55
Weight, kg	26
Pressurized storage tank	100 L
Feed water pressure	0.5 – 4 bar
Feed water conductivity	< 1500 μS/cm

CONSUMABLES

Part number	Description	Replacement criteria	Comments
10410	Replacement pre-filter set, Crystal Clinic	Filter life counter is zero or the filter is clogged	
10113	Replacement high-capacity deionization module	„DI Err” message is shown, or water conductivity is consistently $> 0.1 \mu\text{S}/\text{cm}$	
10011	Replacement sterilization UV bulb	When required (on average every 2 years)	Only systems with 10102 option

FLOW DIAGRAM

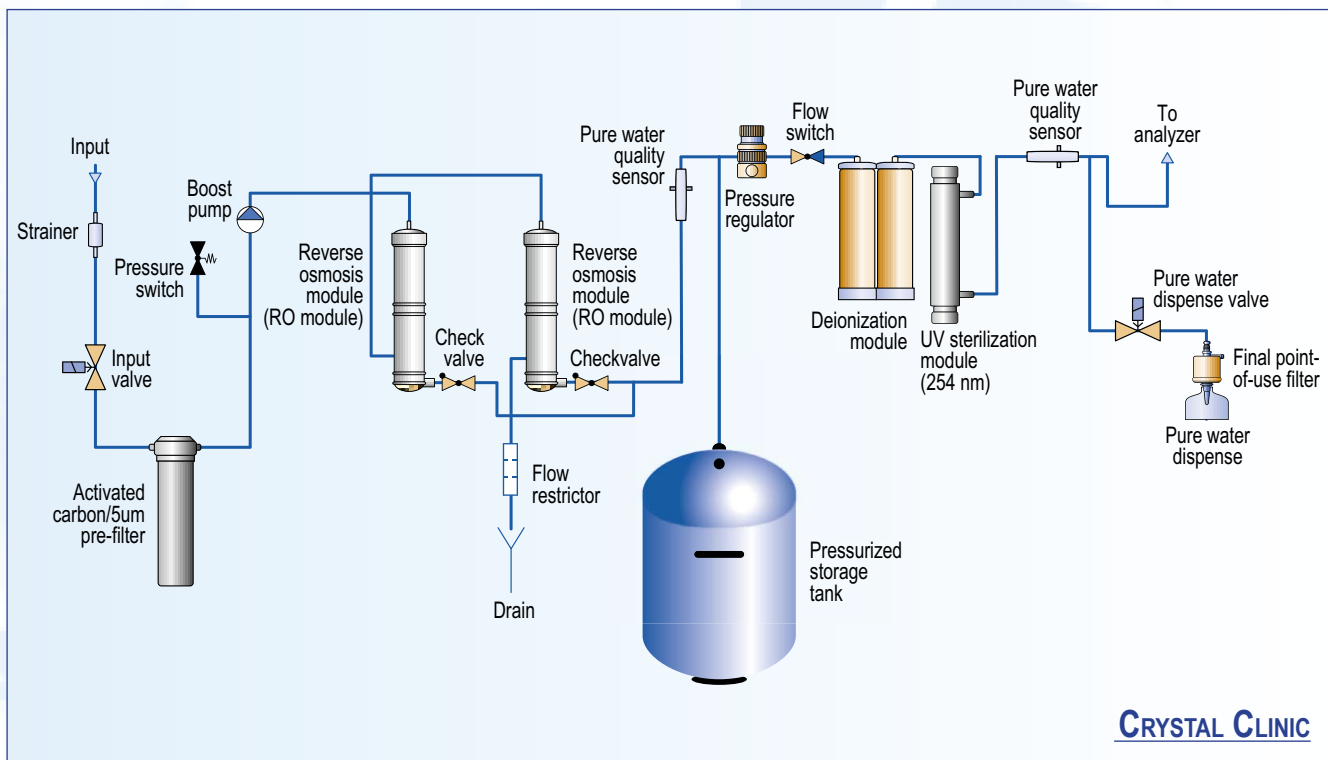

Q-FRONT EDI CLINIC

Q-Front EDI Clinic water purification system is designed to provide supply of deionised water according to specifications of the automated biochemistry analyzers.

It is the second generation of our system dedicated to these applications. The significant improvement of this model is built in Electro Deionisation Module that excludes replacement of deionisation cartridges. It is suitable for biochemistry analyzers with higher capacity where application of previous Crystal Clinic was limited.



ORDERING INFORMATION

Model	Part number
Q-Front 10 EDI Clinic	QF-4208
Q-Front 15 EDI Clinic	QF-4308

CONSUMABLES

Part number	Description
10410	Replacement Pre-filters (all Q-front models)
10319	Replacement pre-filter set, Crystal Clinic
10113	Replacement high capacity deionization module
10011	Replacement sterilization UV bulb (for systems equipped with 10102)

SPECIFICATIONS

Purified water specifications	
Grade 2 water resistivity	>10 MΩ x cm
Grade 2 water conductivity	<0.1 μS/cm

DESCRIPTION

Application	For biochemical analyzers (Grade 2)
Dimensions (WxDxH), cm	35X39X54
Weight, kg	30
Display	16-bit color display
Storage tank	Tank is required, but not included

ACCESSORIES

Model	Part number
Pressurized water storage tank 100L, for CL-2810	10114
Water storage tank "Pro", 30L w/ multipoint sensor complies with QF-4208; QF-4308	11015
Water storage tank "Pro", 30L w/o multipoint sensor complies with QF-4208; QF-4308	13003
Storage tank "Comfort" w/ base, tap and level switch, 100L complies with QF-4208; QF-4308	10027
Storage tank "Comfort" w/base level switch, 200L complies with QF-4208; QF-4308	10026
Storage tank "Comfort" w/base level switch, 300L complies with QF-4208; QF-4308	10025
Water distribution module for QF-4208; QF-4308	13005
Universal remote dispenser with 3m supply hose w/ fixed stand w/o controller, suitable for any pressurised water system	13008



CRYSTAL STERIFEED

Pressurized water storage tank provides consistent water supply to an autoclave. Many autoclaves need pressurized purified water supply. Some autoclaves have priming pumps for purified water intake, but in case the water supply is not pressurized, an air gap may block the water flow. If the blockage occurs, the operation of autoclave is not possible until the air is removed from the system. Pressurized water storage tank of the “Sterifeed” system eliminates any possibility of air gap formation and ensures smooth operation of an autoclave.

Sterifeed is a water purification system that is specially designed to produce feed water for autoclaves.

Sterifeed produces water with conductivity 5-11 $\mu\text{S}/\text{cm}$, that is inside the conductivity range recommended by autoclave vendors. Usually 3-15 $\mu\text{S}/\text{cm}$ is the recommended conductivity range for autoclave feed water for reliable operation of autoclave.

DESCRIPTION

Water type	pure water (Grade 2)
Application	purified water for autoclaves
Display	monochrome LCD display
Conductivity sensor	•
TOC Monitor	-
Measurement validation port	-
Volumetric dispensing	-
Connection to Flow Point	-
Storage tank	pressurized storage tank, 60 L
Installation	installable on a wall

ORDERING INFORMATION

Model	Part number
Crystal Sterifeed	CS-1002

CONSUMABLES

Part number	Description	Replacement criteria	Comments
10016	Replacement pre-filter set, Sterifeed	Filter life counter is zero or the filter is clogged	

FLOW DIAGRAM

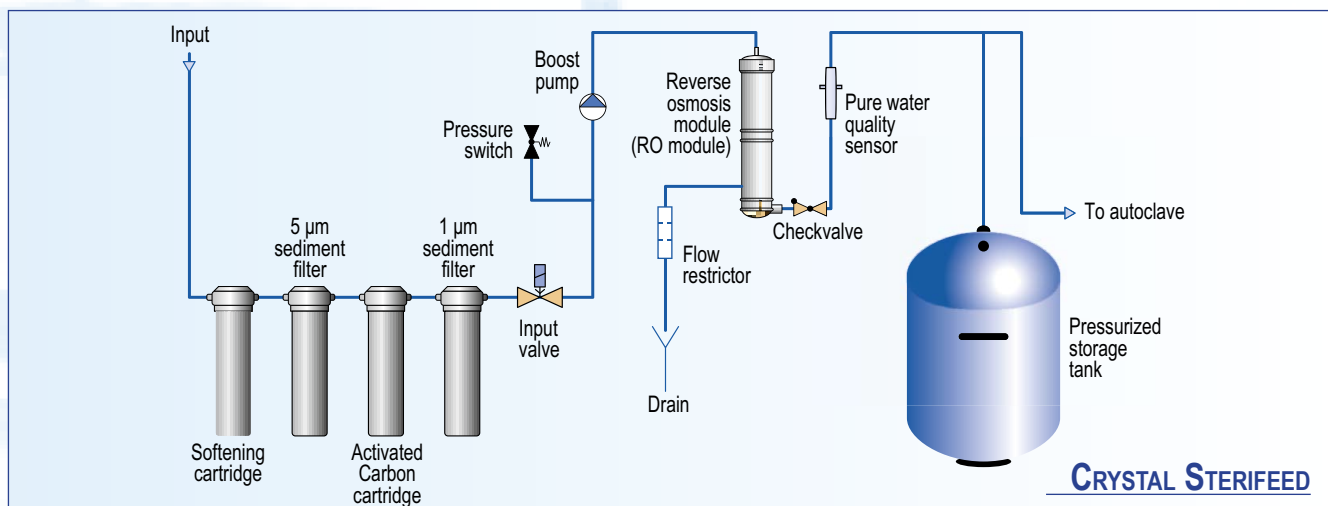

ONSITE+ AND CONNECT SERIES

Onsite+ and Connect are hi-end polishing water purification systems. The feed water must be pre-treated by reverse osmosis or distillation. Systems are recommended for laboratories with average daily consumption of water within 5-10 litres.

Onsite+ series systems contain an embedded tank that has to be filled with pre-treated water before operation. Pre-treated water can be obtained by distillation or reverse osmosis. For user convenience the Onsite+ system comes with additional 5L carboy. The carboy has a stopcock and handle for easy transportation of water from water still to the Onsite+ unit.

Connect series systems should be connected to a water pre-treatment unit or a distilled water distribution system in a lab. The pre-treatment system should maintain water pressure of no less than 1 bar.



ORDERING INFORMATION

Model	Part number
Onsite+ Trace	CB-1901
Onsite+ HPLC	CB-1903
Onsite+ Bio	CB-1905
Connect Trace	CB-1701
Connect HPLC	CB-1703
Connect Bio	CB-1705
Water quality sensor validation kit	10913

DESCRIPTION ONSITE+ SERIES

	Trace	HPLC	Bio
Water type	ultrapure water (Grade 1)	ultrapure water (Grade 1)	ultrapure water (Grade 1)
Application	<ul style="list-style-type: none"> atomic absorption spectrometry plasma optical emission spectrometry other inorganic trace analysis 	<ul style="list-style-type: none"> chromatography mass spectrometry microbiology molecular biology 	highly sensitive biology applications
Display	Color graphic LCD display		
Conductivity sensor	•	•	•
TOC Monitor	-	•	•
Measurement validation port	•	•	•
Volumetric dispensing	•	•	•
Connection to Flow Point	•	•	•
Storage tank	Integrated tank 5L		
Installation	installable either on a laboratory bench or on a wall		

DESCRIPTION CONNECT SERIES

	Trace	HPLC	Bio
Water type	ultrapure water (Grade 1)	ultrapure water (Grade 1)	ultrapure water (Grade 1)
Application	<ul style="list-style-type: none"> • atomic absorption spectrometry • plasma optical emission spectrometry • other inorganic trace analysis 	<ul style="list-style-type: none"> • chromatography • mass spectrometry • microbiology • molecular biology 	highly sensitive biology applications
Display	Color graphic LCD display		
Conductivity sensor	•	•	•
TOC Monitor	option	•	•
Measurement validation port	•	•	•
Volumetric dispensing	•	•	•
Connection to Flow Point	•	•	•
Storage tank	Not included		
Installation	installable either on a laboratory bench or on a wall		

SPECIFICATIONS

Ultrapure water parameters	Onsite+/Connect system configuration		
	Trace	HPLC	Bio
Ultrapure water resistivity	18.2 MΩ x cm	18.2 MΩ x cm	18.2 MΩ x cm
Ultrapure water conductivity	0.055 μS/cm	0.055 μS/cm	0.055 μS/cm
Total Organic Carbon (TOC) level	<10 ppb	<2 ppb	<2 ppb
RNase	-	-	<0.01 ng/mL
DNase	-	-	<4 pg/μL
Bacteria	< 1 CFU/mL	< 1 CFU/mL	< 0.1 CFU/mL
Endotoxins	<0.15 EU/mL	<0.15 EU/mL	< 0.001 EU/mL
Particles >0.22 μm	<1/mL	<1/mL	<1/mL
Polishing module life*	1 m ³	1 m ³	1 m ³
Dimensions (WxDxH), cm	30x44x64	30x44x64	30x44x64
Weight, kg	16	17	17
Feed water conductivity	< 100 μS/cm	< 100 μS/cm	< 100 μS/cm

* Polishing module life depends on feed water quality.

CONSUMABLES

Part number	Description	Replacement criteria	Comments
10030	Polishing module "Polishing+"	When indicated on the display or water conductivity is constantly > 0.1 μS/cm during recirculation	
10018	UV photooxidation bulb	2 years on average	Only for „Bio” and „HPLC”
10012	Point-of-use microfilter	Every 6–12 months	Only for „Trace” and „HPLC”
10120	Point-of-use ultrafilter	Every 3–6 months	Only for „Bio”

FLOW DIAGRAM

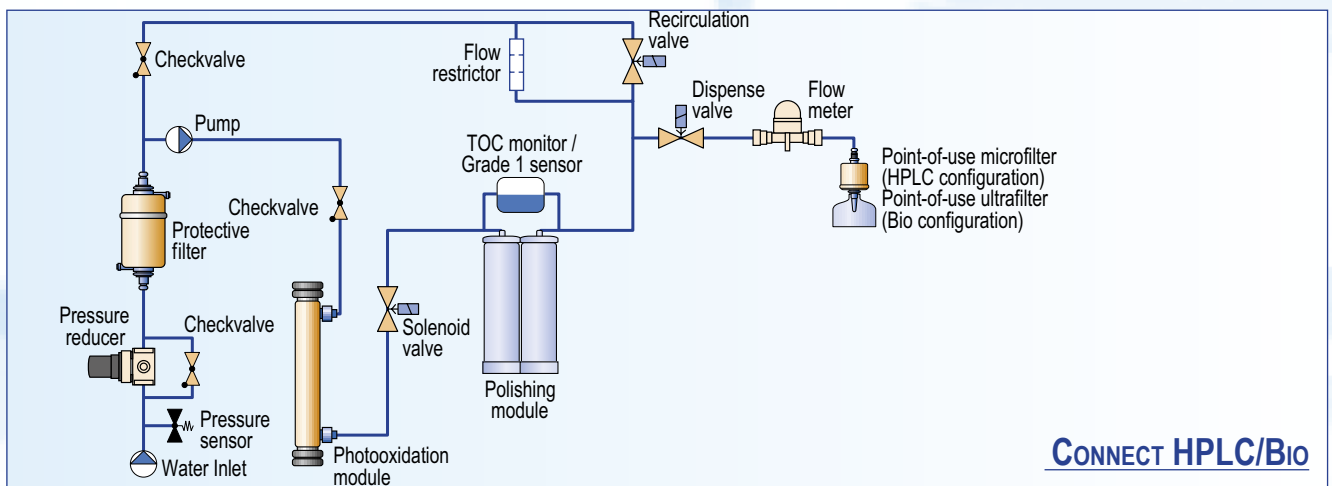
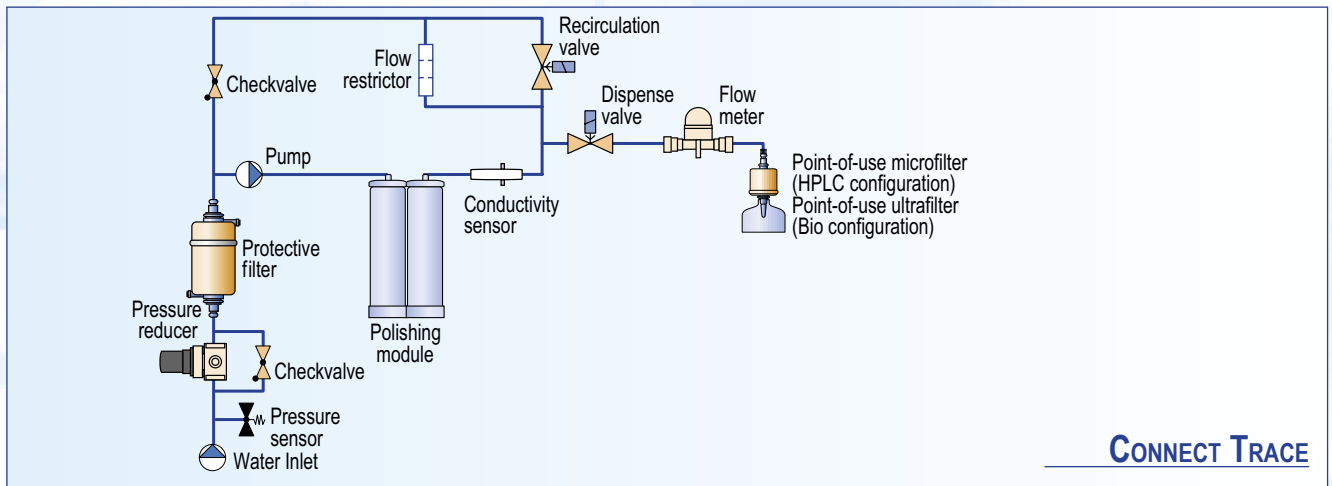
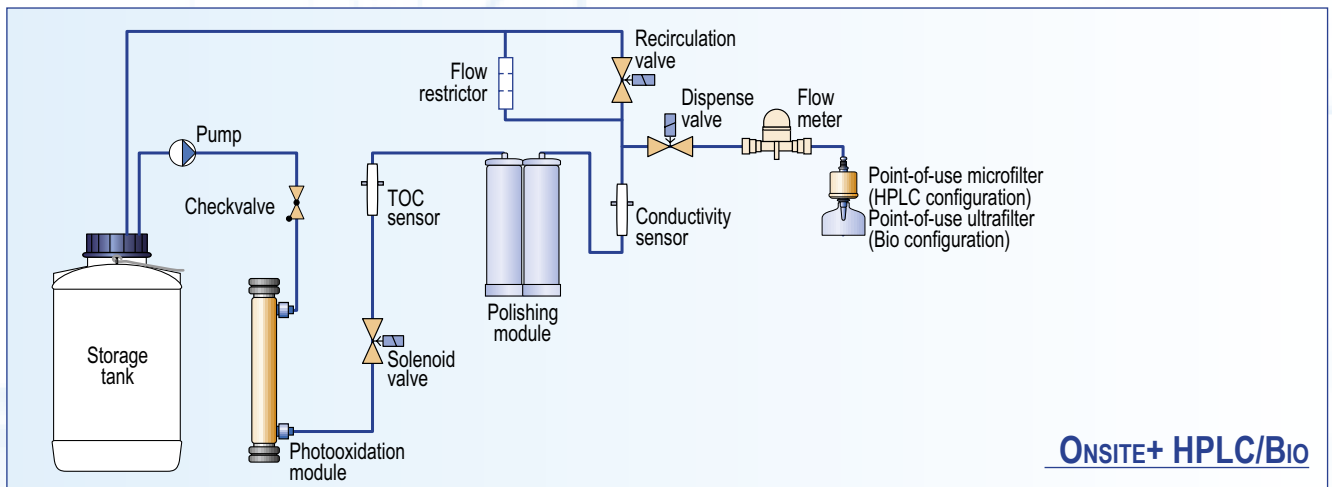
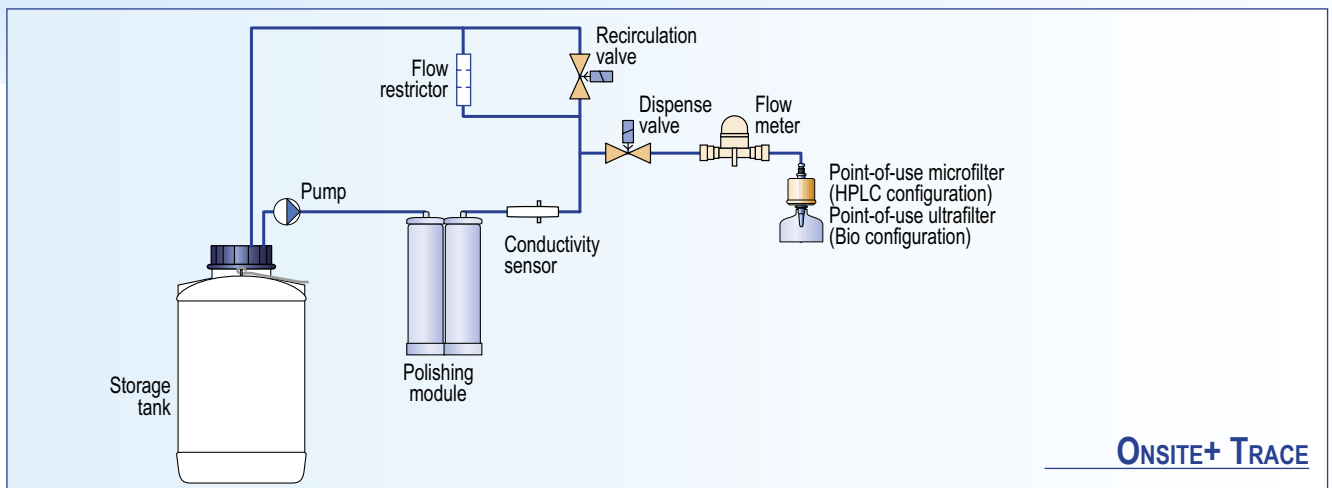



RADIX

New RADIX systems are intended for RO or Grade 2 water supply central laboratory house water distribution systems. It can be connected to atmospheric tanks with level sensors.

DESCRIPTION

	RADIX 60 RO	RADIX 100 RO	RADIX 30 EDI	RADIX 60 EDI
Model	RA1001	RA1003	RA2101	RA2103
Capacity, l/H	60	100	30	60
Average ion rejection rate	99%	99%	-	-
Output water conductivity	-	-	0.2 μ S	0.2 μ S
Display	Controller with color display			
Dimensions (WxDxH), cm	33x65x72	33x65x72	33x65x72	33x65x72
Weight, kg	42	56	50	56

FLOW DIAGRAM

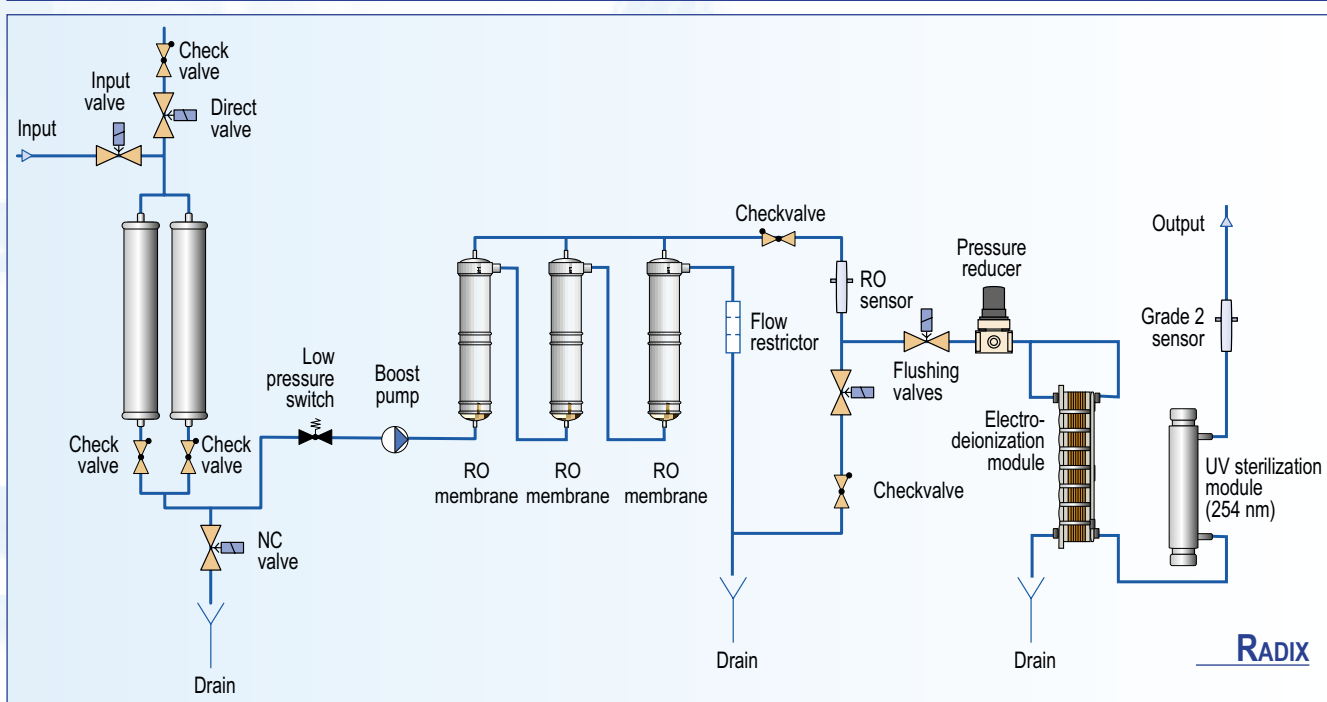

ACCESSORIES

For increased convenience of use of the Adrona water purification systems, choose from the variety of accessories to meet your specific needs.

STORAGE TANKS

Adrona water purification systems can be equipped with water storage tanks of various capacity. Depending on the consumption of purified water, user can choose the tank starting from tank with capacity of 10 litres up to 300 litres. All the storage tanks are equipped with level switch.

WATER STORAGE TANK “PRO”



Specially designed for significant reduction of microbiological contamination possibilities

Features:

- Capacity 30 or 60 litres
- Opaque housing walls for protection against light
- Conical bottom for complete draining
- Ergonomical design
- Equipped with stopcock
- Recirculation system for maintaining the water quality
- Automatic UV sanitization (UV lamp) module (option)
- Multi-position level switch, that enables precise control of remaining water
- Fast pure water dispense pump (option)

WATER DISPENSING UNIT “FLOW POINT 2”



Water dispensing unit provides more convenient use of Adrona systems. One water purification system can be equipped with 2 water dispensing units.

- Adjustable in all dimensions
- Manual and/or volumetric dispensing with teaching mode
- Color graphic LCD display
- Full remote control for water purification system
- Compatible with Q-Front, B30, Onsite+, Integrity+ and Connect systems

ORDERING INFORMATION

Model	Part number
Water storage tank “Pro” w/multi- position level switch, 30 L	11015
Water storage tank “Pro” w/multi-position level switch, 60 L	11016
Water storage tank “Comfort” w/ level switch, w/ base, 60 L	10007
Water storage tank “Tiny” w/ level switch, dispense tap, 10L	11014
Storage tank “Comfort” w/ dispense pump, w/ base, 100L	10027
Storage tank “Comfort” w/ dispense pump, w/ base, 200L	10026
Storage tank “Comfort” w/ dispense pump, w/ base, 300L	10025
Automatic sanitization module for tank	10315
Water dispensing unit	10325
Universal remote dispenser	13008

**WATER STORAGE TANK
"PRO" 60 L**



**WATER STORAGE TANK
"COMFORT" 60 L**



LABORATORY WATER SYSTEM SERVICE ACCESSORIES

Part number	Model	Specification
2CA100	Conductometer WTW cond 3110	0.00-20.00 MΩ x cm 0.001-200 μS/cm
301961	Utrapure water conductivity cell	
91220	Hardness test strips	
HI98308	Conductivity tester PWT	0.00-99.9 μS/cm
HI98304	Conductivity tester DIST4	0.00-20 mS/cm



MD Scientific is an authorized distributor in Denmark
www.md-scientific.dk - +45 7027 8565

ISO 9001

BUREAU VERITAS
Certification



adrona

Dzerbenes 27, Riga
LATVIA, LV – 1006
Tel.: +371 67551894, +371 67551993
Fax: +371 67551976
e-mail: info@adrona.lv
www.adrona.eu