

HSL Filter Housings

Sanitary Liquid



- Single element sanitary liquid housing
- Designed specifically for the food & beverage and pharmaceutical industries
- Sanitary tri-clamp body closure as standard
- STANDARD product
 - Sanitary surface finish
 - Tri-clamp connections
- PLUS product
 - Available in 3 different vessel classes: Standard (CE), Atex and High Pressure
 - Sanitary or sanitary electropolished surface finish options
 - Wide range of vent and drain connections
 - Choice of gasket and seal materials

Specification

STANDARD Range

Materials of Construction

- Housing: 316L Stainless Steel
- Seals: Silicone FDA
- Clamps: 304 Stainless Steel

Surface Finish

- Internal: Polished 0.4 $\mu\text{m Ra}$ (16 $\mu\text{In Ra}$)
- External: Polished 0.25 $\mu\text{m Ra}$ (10 $\mu\text{In Ra}$)

All finishes pickled & passivated.

PLUS Range

Materials of Construction

- Housing: 316L Stainless Steel
- Seals: EPDM FDA
PTFE FDA
Silicone FDA
Viton® / FKM FDA
- Clamps: 304 Stainless Steel

Surface Finish

- Sanitary Finish
 - Internal: Polished 0.4 $\mu\text{m Ra}$ (16 $\mu\text{In Ra}$)
 - External: Polished 0.25 $\mu\text{m Ra}$ (10 $\mu\text{In Ra}$)

- Sanitary Electropolished Finish

- Internal: Electropolished 0.4 $\mu\text{m Ra}$ (16 $\mu\text{In Ra}$) and Electropolished
- External: Polished 0.25 $\mu\text{m Ra}$ (10 $\mu\text{In Ra}$)

Welding

All assembly welds are full penetration. All welds are crevice and undercut free. Weld finish & detail drawings available upon request.

Certification

Supplied as standard with vessel inspection certificate.

Material Test Certification

EN10204 3.1 supplied upon request.

Design Code

Housings designed in accordance with the European Council Pressure Equipment Directive (PED) 97/23/EC and the UK statutory Pressure Equipment Regulations (PER) 1999 N° 2001.

Design Basis

ASME VIII Division 1.

HSL Filter Housings Sanitary Liquid

Standard Range

Working Condition PED 97/23/EC			Maximum Pressure				
Fluid Group	State	Temperature	01A	01B	011	012	013
Non Dangerous	Liquid / Gas	150 °C (302 °F)	10 barg (145 psig)	10 barg (145 psig)	10 barg (145 psig)	10 barg (145 psig)	10 barg (145 psig)
Dangerous	Liquid / Gas	150 °C (302 °F)	10 barg (145 psig)	10 barg (145 psig)	5 barg (72.5 psig)	5 barg (72.5 psig)	5 barg (72.5 psig)
PED Conformity Assessment Category			SEP	SEP	SEP	SEP	CAT I
Volume (litres)			0.75	0.5	2.9	4.8	6.7

Plus Range

CE Working Condition PED 97/23/EC			Maximum Pressure						
Fluid Group	State	Temperature	01A	01B	01K	011	012	013	014
Non Dangerous	Gas / Vapour	150 °C (302 °F)	10 barg (145 psig)	10 barg (145 psig)	10 barg (145 psig)	10 barg (145 psig)	10 barg (145 psig)	10 barg (145 psig)	10 barg (145 psig)
Dangerous	Gas / Vapour	150 °C (302 °F)	10 barg (145 psig)	10 barg (145 psig)	5 barg (72.5 psig)	5 barg (72.5 psig)	5 barg (72.5 psig)	5 barg (72.5 psig)	5 barg (72.5 psig)
Non Dangerous	Liquid	150 °C (302 °F)	10 barg (145 psig)	10 barg (145 psig)	10 barg (145 psig)	10 barg (145 psig)	10 barg (145 psig)	10 barg (145 psig)	10 barg (145 psig)
Dangerous	Liquid	150 °C (302 °F)	10 barg (145 psig)	10 barg (145 psig)	5 barg (72.5 psig)	5 barg (72.5 psig)	5 barg (72.5 psig)	5 barg (72.5 psig)	5 barg (72.5 psig)
PED Conformity Assessment Category			SEP	SEP	SEP	SEP	SEP	CAT I	CAT I
Volume (litres)			0.75	0.5	1.7	2.9	4.8	6.7	8.6

ATEX Working Condition PED 97/23/EC			Maximum Pressure						
Fluid Group	State	Temperature	01A	01B	01K	011	012	013	014
Non Dangerous	Gas / Vapour	135 °C (275 °F)	10 barg (145 psig)	10 barg (145 psig)	10 barg (145 psig)	10 barg (145 psig)	10 barg (145 psig)	10 barg (145 psig)	10 barg (145 psig)
Dangerous	Gas / Vapour	135 °C (275 °F)	10 barg (145 psig)	10 barg (145 psig)	5 barg (72.5 psig)	5 barg (72.5 psig)	5 barg (72.5 psig)	5 barg (72.5 psig)	5 barg (72.5 psig)
Non Dangerous	Liquid	135 °C (275 °F)	10 barg (145 psig)	10 barg (145 psig)	10 barg (145 psig)	10 barg (145 psig)	10 barg (145 psig)	10 barg (145 psig)	10 barg (145 psig)
Dangerous	Liquid	135 °C (275 °F)	10 barg (145 psig)	10 barg (145 psig)	5 barg (72.5 psig)	5 barg (72.5 psig)	5 barg (72.5 psig)	5 barg (72.5 psig)	5 barg (72.5 psig)
PED Conformity Assessment Category			SEP	SEP	SEP	SEP	SEP	CAT I	CAT I
Volume (litres)			0.75	0.5	1.7	2.9	4.8	6.7	8.6

High Pressure Working Condition PED 97/23/EC			Maximum Pressure						
Fluid Group	State	Temperature	01A	01B	01K	011	012	013	014
Non Dangerous	Gas / Vapour / Liquid	205 °C (401 °F)	16 barg (232 psig)	16 barg (232 psig)	16 barg (232 psig)	16 barg (232 psig)	16 barg (232 psig)	16 barg (232 psig)	16 barg (232 psig)
PED Conformity Assessment Category			SEP	SEP	SEP	SEP	CAT I	CAT I	CAT I
Volume (litres)			0.75	0.5	1.7	2.9	4.8	6.7	8.6

Note: All housings are full vacuum rated.

HSL Filter Housings

Sanitary Liquid



Physical Characteristics

Bowl Height	Dimensions (mm)			Typical Weight
	'A'	'B'	'C'	
A Size 125 mm (5")	117 mm (4.6")	191 mm (7.5")	130 mm (5.1")	2.0 Kg (4.4lbs)
B Size 65 mm (2 1/2")	117 mm (4.6")	136 mm (5.4")	70 mm (2.8")	1.8 Kg (3.9lbs)
250 mm (10")	156 mm (6.1")	417 mm (16.4")	313 mm (12.3")	3.8 Kg (8.3 lbs)
500 mm (20")	156 mm (6.1")	667 mm (26.3")	561 mm (22.1")	4.8 Kg (10.5 lbs)
750 mm (30")	156 mm (6.1")	912 mm (35.9")	809 mm (31.8")	5.7 Kg (12.5 lbs)
1000 mm (40")	156 mm (6.1")	1160 mm (45.7")	1057 mm (41.6")	6.7 Kg (14.7 lbs)

Dimensions shown are based on the STANDARD range. For accurate dimensions, please contact Parker domnick hunter.

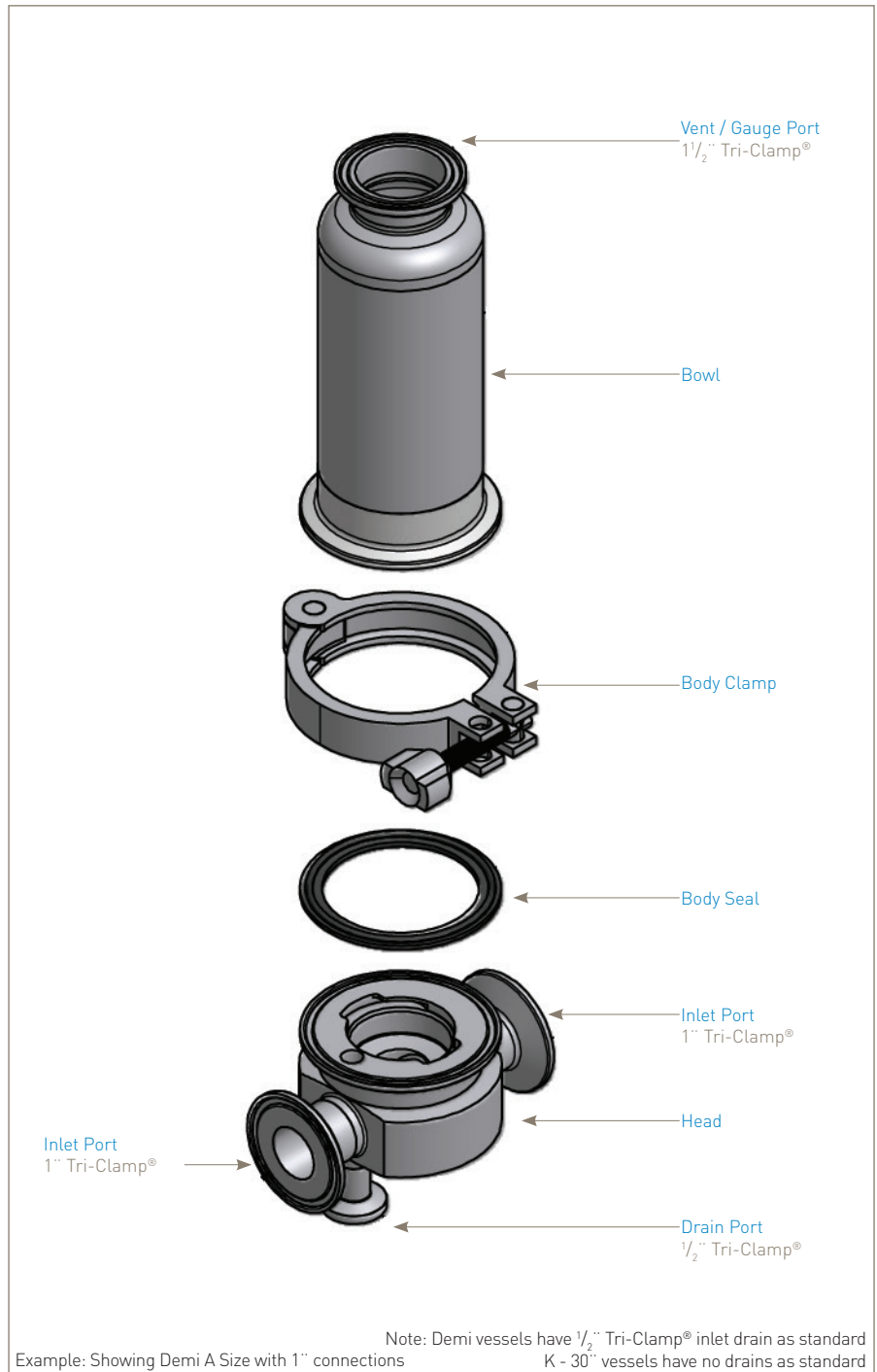
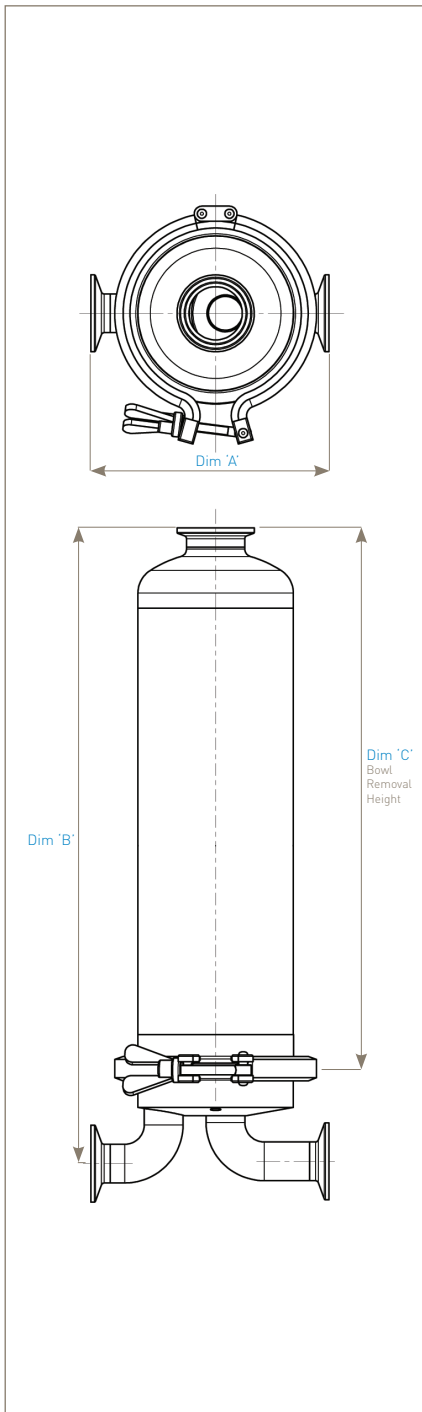

Note: Demi vessels have 1/2" Tri-Clamp® inlet drain as standard
 Example: Showing Demi A Size with 1" connections
 K - 30" vessels have no drains as standard

The PLUS product range is available with many options of connections, vents, drains, surface finish, seals classification, etc. Please see product coding.

HSL Filter Housings Sanitary Liquid

STANDARD Range - 10" to 30"

HSL [] 01 [] [] [] - [] - []

Code Vessel Class	Code Length (Nominal)	Code Connection Size	Code Standard	Code Cartridge	Code Seal
CE Standard	1 10" (250 mm) 2 20" (500 mm) 3 30" (750 mm)	B 1" (25.4 mm)	T Tri-Clamp®	C 226	S Silicone

Note: No drain(s) as standard.

STANDARD Range - Demi A & B

HSL [] 01 [] [] [] - [] - []

Code Vessel Class	Code Length (Nominal)	Code Connection Size	Code Standard	Code Cartridge	Code Seal
CE Standard	A 5" (125 mm) B 2 1/2" (65 mm)	B 1"	T Tri-Clamp®	T 126	S Silicone

Note: 1/2" Tri-Clamp® inlet drain as standard.

PLUS Range - K to 40"

HSL [] 01 [] [] [] [] [] [] - [] [] - [] [] - [] []

Code Vessel Class	Code Length (Nominal)	Code Connection Size	Code Standard	Code Cartridge	Code Seal	Code Vent	Code Drain
CE Standard AT ATEX HP* High Pressure	K 5" (125 mm) 1 10" (250 mm) 2 20" (500 mm) 3 30" (750 mm) 4 40" (1000 mm)	B 1" (25.4 mm)	D DIN11851(M) F ⁽¹⁾⁽²⁾ ANSI RF 150 H ⁽²⁾ ANSI RF 300 L ⁽²⁾ FLANGE ISO / DIN R RJT(M) S SMS Union (M) T Tri-Clamp® W Butt Weld BS4825 Pt.1	C 226	E EPDM P* PTFE S Silicone V Viton® / FKM	A 1 1/2" Tri-Clamp® & 2 x Rectus 21 E 1 1/2" Tri-Clamp® & 2 x Stäubli™ RBE03 H 1 1/2" Tri-Clamp® & Hosebarb I 1 1/2" Tri-Clamp® & Stäubli™ RBE03 M 1 1/2" Tri-Clamp® & 1/2" Tri-Clamp® R 1 1/2" Tri-Clamp® & Rectus 21 S Stäubli™ RBE03 Vertical T 1 1/2" Tri-Clamp® Only	H Hosebarb Inlet Only R Rectus 21 Inlet Only S Stäubli™ RBE03 Inlet Only X No Drain Y 1" Tri-Clamp® Inlet Only Z 1" TCF Inlet & Outlet

* Supplied complete with a double bolted clamp

⁽¹⁾ Not suited for High Pressure Vessels. HP Vessels to use ANSI RF 300.
⁽²⁾ Flanged vessels based on 1" O.D. pipe but use 1/4" or NW20 flanges.

Code Surface Finish	Internal	External
B Sanitary	0.4 µm	0.25 µm
P Sanitary Electropolished	0.4 µm EP	0.25 µm

Code Tagged	Yes	No
T	Yes	No
X	No	Yes

For Tagged Options customer identification numbers required at time of ordering

PLUS Range - Demi A & B

HSL [] 01 [] [] [] [] [] [] - [] [] - [] [] - [] []

Code Vessel Class	Code Length (Nominal)	Code Connection Size	Code Standard	Code Cartridge	Code Seal	Code Vent	Code Drain
CE Standard AT ATEX HP High Pressure	A 5" (125 mm) B 2 1/2" (65 mm)	B 1"	D DIN11851 F ⁽¹⁾⁽²⁾ ANSI RF 150 H ⁽²⁾ ANSI RF 300 L FLANGE ISO / DIN R RJT S SMS Union (M) T Tri-Clamp® W Butt Weld BS4825 Pt.1	T 126	E EPDM P* PTFE S Silicone V Viton™ / FKM	A 1 1/2" Tri-Clamp® & 2 x Rectus 21 B 1 1/2" Tri-Clamp® & 2 x Stäubli RBE03 H 1 1/2" Tri-Clamp® & Hosebarb I 1 1/2" Tri-Clamp® & Stäubli RBE03 M 1 1/2" Tri-Clamp® & 1/2" TCF R 1 1/2" Tri-Clamp® & Rectus 21 S Stäubli RBE03 T 1 1/2" Tri-Clamp® Only	H Hosebarb Inlet Only R Rectus 21 Inlet Only S Stäubli RBE03 Inlet Only T 1/2" Tri-Clamp® Inlet Only X No Drain

⁽¹⁾ Not suited for High Pressure Vessels. HP Vessels to use ANSI RF 300.
⁽²⁾ Only available in 1/4".

Code Surface Finish	Internal	External
B Sanitary	0.4 µm	0.25 µm
P Sanitary Electropolished	0.4 µm EP	0.25 µm

Code Tagged	Yes	No
T	Yes	No
X	No	Yes

For Tagged Options customer identification numbers required at time of ordering

Stäubli™ is a trademark of Stäubli AG.

Tri-Clamp® is a trademark of Alfa-Laval, Inc.

Viton® is a registered trademark of DuPont Performance Elastomers L.L.C..



01422 377367



enquiries@prosep.co.uk

PROSEP
FILTER SYSTEMS LTD

WE ARE YOUR **'ONE STOP SHOP'** FOR ALL
OF YOUR FILTRATION REQUIREMENTS

LIQUID FILTRATION

- CARTRIDGES
- FILTER BAGS
- VESSELS
- STRAINERS

AIR FILTRATION

- VENT FILTERS
- STERILE AIR
- VACCUM
- AIR-CONDITIONING
- FILTER MEDIA

DOMESTIC

- ULTRAVIOLET
- TREATMENT OF BOREHOLES,
SPRINGS & WELLS
- WATER TESTING

FUEL FILTRATION

- DIESEL, AVIATION



Prosep Filter Systems Ltd
Unit G19, River Bank Way,
Lowfields Business Park,
Elland, West Yorkshire
HX5 9DN

Phone: 01422 377367
email: sales@prosep.co.uk
www.prosep.co.uk



for all your filter requirements